

AIDE-MEMOIRE TECHNIQUE
TECHNISCHES DATENBUCH
TECHNICAL DATA HANDBOOK
MEMENTO TECNICO
PRONTUARIO TECNICO

N° 586/3

L'AIDE-MEMOIRE TECHNIQUE est un document rassemblant toutes les données numériques nécessaires à l'entretien, aux réglages et à la réparation des véhicules CITROEN.

Les véhicules traités dans ce document sont ceux du type «FRANCE». Pour les chapitres «CARACTERISTIQUES VEHICULES» se reporter aux documents «d'homologation nationale» du pays considéré.

Un fascicule complet sera édité chaque année, et comportera toujours un intercalaire avec onglet, ce qui permet différents modes de classement dans des couvertures du type «MULTO» soit groupement des différentes années d'un même véhicule, soit groupement des différents modèles de la même année sous une même couverture.

Une mise à jour pourra être faite en cas de modification des données techniques en cours d'année.

DAS TECHNISCHE DATENBUCH ist ein Leitfaden, in welchem alle notwendigen zahlenmäßigen Angaben zur Pflege, zur Einstellung und zur Reparatur der CITROEN-Fahrzeuge enthalten sind.

Die in diesem Datenbuch behandelten Fahrzeuge sind die vom Typ «FRANKREICH». Hinsichtlich der Kapitel «FAHRZEUGMERKMALE» halte man sich an die «nationale Betriebslaubnis» des betreffenden Landes.

Ein komplettes Heft wird jedes Jahr neu herausgegeben und enthält stets ein Zwischenblatt mit Register, wodurch sich verschiedene Arten von Einordnen in Deckel nach Art der «MULTO»-Ordner ergeben, z. B. Zusammenfassung mehrerer Jahre für das gleiche Fahrzeug oder Zusammenfassung verschiedener Fahrzeugtypen des gleichen Jahres unter ein und demselben Deckel.

Eine Berichtigung im Falle von Änderungen der technischen Daten kann im Laufe des Jahres erfolgen.

The **TECHNICAL DATA HANDBOOK** summarises all the numerical information necessary for the maintenance, adjustment and repair of **CITROEN** vehicles.

Data quoted in this handbook deals with French market vehicles. For features specific to other countries, refer to the official homologation sheets of the countries concerned.

A complete booklet will be issued each year, and will always have a tabbed spacer-card, so that various ways of filing in a «**MULTO**» binder can be used, such as keeping in one binder the successive years' booklets concerning one model, or all the different booklets covering all models issued in one year.

An amendment may be issued if a specification change is introduced during a model-year.

EL MEMENTO TECNICO es un documento que examina cuidadosamente todos los datos numéricos necesarios para el entretenimiento, los reglajes y la reparación de los vehículos **CITROEN**.

Los vehículos tratados en este documento son los del tipo «FRANCES». Para los capítulos «CARACTERISTICAS DE LOS VEHICULOS» consultar los documentos «de homologación nacional» del país considerado.

Un fascículo completo será editado cada año, y comportará siempre un intercalador con ñeta, lo que permitirá varias formas de clasificación en las tapas tipo «**MULTO**», bien sea agrupando los diferentes años de un mismo vehículo, o bien agrupando los diferentes modelos de un mismo año en unas mismas tapas.

Una puesta al día puede hacerse en caso de modificaciones de los datos técnicos en el transcurso del año.

II PRONTUARIO TECNICO è un documento che riassume tutti i dati tecnici relativi alla manutenzione, la regolazione e la riparazione dei veicoli **CITROEN**.

I veicoli trattati nella presente pubblicazione sono del tipo «FRANCIA». Per i capitoli «CARATTERISTICHE DEI VEICOLI» riportarsi ai documenti di «omologazione nazionale» di ciascun paese interessato.

Ogni anno verrà pubblicato un fascicolo completo munito di separatore ad unghietta, ciò che permetterà di adottare diversi tipi di classificazione tramite classificatori «**MULTO**»: sia raggruppando le varie annate di uno stesso veicolo, sia radunando i vari modelli di uno stesso anno sotto un'unica copertina.

Durantel'anno, in caso di modifiche dei dati tecnici, potrà essere effettuato il relativo aggiornamento.

REPertoire - INHALTSVERZEICHNIS - INDEX - INDICE - REPERTORIO

GENERALITES (N° de châssis)	Allgemeines (Fahrgestell - N°)	General Information (Chassis N°)	A
	Generalidades (N° de chasis)	Generalità (N° telaio)	
CARACTERISTIQUES VEHICULES	Technische Daten der Fahrzeuge	Vehicle Characteristics	00
	Características de los vehículos	Caratteristiche veicoli	
CARACTERISTIQUES MOTEUR	Technische Daten des Motors	Engine Characteristics	10
	Características del Motor	Caratteristiche motore	
PARTIES FIXES MOTEUR	Motor, Gehäuse	Engine, Fixed Components	11
	Partes fijas del Motor	Parti fisse motore	
PARTIES MOBILES MOTEUR	Motor, Bewegliche Teile	Engine, Moving Components	12
	Partes móviles del Motor	Parti mobili motore	
ALIMENTATION	Kraftstoffzufuhr	Fuel Supply	14
	Alimentación	Alimentazione	
ACCESSOIRES D'ALIMENTATION	Zubehorteile für die Kraftstoffzufuhr	Fuel Supply Accessories	17
	Accesorios de la alimentación	Accessori alimentazione	
ALLUMAGE	Zündanlage	Ignition	21
	Encendido	Accensione	
GRAISSAGE (circuit d'huile moteur)	Schmierung (Schmierkreislauf des Motors)	Lubrication (Engine Oil Circuit)	22
	Engrase (Circuito de aceite del motor)	Lubrificazione (Circuito olio motore)	
REFROIDISSEMENT	Kühlsystem	Cooling	23
	Refrigeración	Raffreddamento	
EMBRAYAGE	Kupplung	Clutch	31
	Embrague	Frizione	
BOITE DE VITESSES	Getriebe	Gear Box	33
	Caja de cambios	Scocca cambio	
COUPLE CONIQUE - DIFFERENTIEL	Kegel- und Tellerad-Differential	Crown-Wheel and Pinion-Differential	34
	Grupo cónico - Diferencial	Coppia conica - Differenziale	
TRANSMISSION	Kraftübertragung	Transmission	37
	Transmisión	Trasmisore	
HYDRAULIQUE	Hydraulik	Hydraulic System	39
	Hidráulica	Idrraulica	
ESSIEU DIRECTEUR	Vorderachse	Steering Axle	41
	Eje director	Assale anteriore	
ESSIEU NON DIRECTEUR	Hinterachse	Non-steering Axle	42
	Eje no director	Assale posteriore	
SUSPENSION	Federung	Suspension	43
	Suspensión	Sospensione	
DIRECTION	Lenkung	Steering	44
	Dirección	Stezo	
FREINS	Bremsen	Brakes	45
	Frenos	Freni	
ELECTRICITE	Elektrische Anlage	Electrical System	53
	Electricidad	Impianto elettrico	
AERATION - CHAUFFAGE	Lüftung - Heizung	Ventilation - Heating	64
	Ventilación - Calefacción	Aerazione - Riscaldamento	
CHASSIS - PLATE-FORME - CAISSE	Fahrgestell - Rahmen - Wagenkasten	Chassis - Platform - Body	70
	Chasis - Plataforma - Carroceria	Telaio - Piattaforma - Scocca	
ENTRETIEN (Station-Service)	Pflege und Wartung (Wartungsdienst)	Maintenance (Service-Station)	E
	Entretienimiento (Estación-Service)	Manutenzione (Stazione-Servizio)	

1	MANUEL DE REPARATIONS REPARATURHANDBUCH REPAIR MANUAL MANUAL DE REPARACIONES MANUALE DI RIPARAZIONE	} 559/1	OPERATIONS ARBEITSVORGÄNGE OPERATIONS OPERACIONES OPERAZIONI	} AM3 - 000a AMB3 - 000	AMI 8 { BERLINE (AM série JA) BREAK (AM série JB) BREAK COMMERCIAL (AM série JB) BREAK SERVICE (AM série JC)	} 9-1969 →
MOTEUR - MOTOR - ENGINE - MOTOR - MOTORE - M 28						

NUMEROS DE CHASSIS - FAHRGESTELLNUMMERN - CHASSIS NUMBERS - NUMEROS DE CHASIS - NUMERI DI TELAIO

TYPE DE VEHICULE FAHRZEUGTYP TYPE OF VEHICLE TIPO DE VEHICULO TIPO DI VEICOLO	PREMIER N° ATTRIBUE AU COURS DE L'ANNEE AUTOMOBILE Ab FAHRGESTELL - Nr. : FIRST NUMBER ALLOCATED IN MODEL YEAR PRIMER NUMERO ATRIBUIDO DURANTE EL AÑO AUTOMOVIL PRIMO NUMERO DELLA SERIE
	1970
AMI 8 - BERLINE AM série JA } AMI 8 - BREAK AM série JB AMI 8 - BREAK COMMERCIAL AM série JB AMI 8 - BREAK SERVICE AM série JC)	00 JA 0003 02 JA 0001 02 JA 0001 00 JB 0003 00 JC 0003

1	MANUEL DE REPARATIONS REPARATURHANDBUCH REPAIR MANUAL MANUAL DE REPARACIONES MANUALE DI RIPARAZIONE	OPERATIONS ARBEITSVORGÄNGE OPERATIONS OPERACIONES OPERAZIONI	AM3 - 000 AM3 - 000a AMB3 - 000	AMI 8 { BERLINE (AM série JA) BREAK (AM série JB) }	N° 559/1	9 - 1969
CARACTERISTIQUES GENERALES	ALLGEMEINE MERKMALE	GENERAL CHARACTERISTICS	CARACTERISTICAS GENERALES	CARATTERISTICHE GENERALI	BERLINE AM série JA	BREAK AM série JB
Designation aux Mines	Technische Überwachungsbezeichnung	Official symbol	Designación en la delegación de industria	Denominazione di omologazione	AM série JA	AM série JB
Appellation commerciale	Handelsbezeichnung	Commercial symbol	Denominación comercial	Denominazione commerciale	AMI 8	AMI 8 BREAK
Symbole usine	Werksbezeichnung	Factory symbol	Símbolo de fabrica	Simbolo d'officina	AM3	AMF 3
Date de sortie	Ausstoss-Datum	Introduced	Fecha de salida	Data di uscita	9-1969	
Genre : VP	Type : PKW	Type : Private car	Tipo : V.P.	Tipo : Berlina		
Puissance administrative	Steuer - PS	French fiscal rating	Potencia fiscal	Potenza fiscale	3 CV	
Nombre de places	Sitzplätze	Number of seats	Número de plazas	Numero posti	4	4/5
Empattement	Radstand	Wheelbase	Distancia entre ejes	Passo	2,400 m (7 ft 10 1/2 in.)	
Voie avant	Spur, vorn	Track front	Ancho de vía delantera	Carreggiata ant.	1,260 m (4 ft 1 5/8 in.)	
Voie arrière	Spur, hinten	Track rear	Ancho de vía trasera	Carreggiata post.	1,220 m (4 ft 0 in.)	
Longueur hors tout	Länge über alles	Length overall	Longitud máxima	Lunghezza massima	3.991 m (13 ft 1 1/2 in.)	
Largeur hors tout	Breite über alles	Width overall	Anchura máxima	Larghezza massima	1,524 m (5 ft 0 in.) 1.554 m (AM-PA) (5 ft 1 1/8 in.)	

2	MANUEL DE REPARATIONS REPARATURHANDBUCH REPAIR MANUAL MANUAL DE REPARACIONES MANUALE DI RIPARAZIONE	N° 559/1	OPERATIONS ARBEITSVORGÄNGE OPERATIONS OPERACIONES OPERAZIONI	AM3 - 000 AMB3 - 000	AMI 8	BERLINE (AM série JA) BREAK (AM série JB)	9 - 1969 →
---	---	----------	--	-------------------------	-------	--	---------------

CARACTERISTIQUES GENERALES (suite)	ALLGEMEINE MERKMALE (Forts.)	GENERAL CHARACTERISTICS (continued)	CARACTERISTICAS GENERALES (continuación)	CARATTERISTICHE GENERALI (seguito)	BERLINE AM série JA	BREAK AM série JB
Hauteur hors tout (à vide)	Höhe über alles	Height overall (unladen)	Altura máxima de carro- ceria (en vacío)	Altezza massima (a vuoto)	1,494 m (4 ft 10 3/4 in.)	1,520 m (4 ft 11 3/4 in.)
Garde au sol (en charge)	Bodenfreiheit unter Belastung	Ground clearance (laden)	Distancia al suelo (en carga)	Distanza dal suolo (a carico)	0,130 m (5 1/8 in.)	0,130 m (5 1/8 in.)
Diamètre de braquage (environ)	Wendekreis - ϕ (ungefähr)	Turning diameter (approx.)	Diámetro de giro (aprox.)	Diametro di sterzata (circa)	11,400 m (37 ft 4 in.)	
DIMENSIONS INTERIEURES	INNERE ABMESSUNGEN	INSIDE DIMENSIONS	DIMENSIONES INTERIORES	DIMENSIONI INTERNE		
Longueur (à hauteur des dossiers)	Länge (in Höhe der Rückenlehne)	Length (at height of seat back)	Longitud (a altura del respaldo)	Lunghezza (all'altezza degli schienali)	2,440 m (8 ft)	2,450 m (8 ft 0 3/8 in.)
Largeur (à hauteur des dossiers)	Breite (in Höhe der Rückenlehne)	Width (at height of seat back)	Anchura (a altura del respaldo)	Larghezza (all'altezza degli schienali)	1,340 m* (4 ft 4 3/4 in.) 1,300 m** (4 ft 3 1/2 in.)	1,340 m* (4 ft 4 3/4 in.) 1,300 m** (4 ft 3 1/8 in.)
Hauteur	Höhe	Height	Alto	Altezza	1,09 m (3 ft 7 3/8 in.)	1,110 m (3 ft 7 3/4 in.)
* à l'avant ** à l'arrière	* vorn ** hinten	* - At the front ** - At the rear	* - delantero ** trasero	* Anteriore ** Posteriore		

3		MANUEL DE REPARATIONS REPARATURHANDBUCH REPAIR MANUAL MANUAL DE REPARACIONES MANUALE DI RIPARAZIONE		N° 559/1		OPERATIONS ARBEITSVORGÄNGE OPERATIONS OPERACIONES OPERAZIONI		AM3 - 000 AMB3 - 000		AMI 8		{ BERLINE (AM série JA) BREAK (AM série JB) }		9-1969 →	
CARACTERISTIQUES GENERALES (suite)		ALLGEMEINE MERKMALE (Forts.)		GENERAL CHARACTERISTICS (continued)		CARACTERISTICAS GENERALES (continuación)		CARATTERISTICHE GENERALI (seguito)		BERLINE AM série JA		BREAK AM série JB			
CAPACITES DE REMORQUAGE Remorque sans dispositif de freinage Remorque avec frein à inertie Poids sur la rotule Pente maximum pour démarrage en charge Poids maxi sur galerie de toit Poids du véhicule car- rossé en ordre de marche - sur l'avant - sur l'arrière Charge utile Poids total maxi autorisé en charge - sur l'avant - sur l'arrière * Véhicules AM série JA ** Véhicules AM série JA PA		ZULÄSSIGE ANHÄNGE- LASTEN Ungebremst Gebremst Gewicht auf Kugelkopt Maxi. Steigung beim An- fahren unter voller Belastung Zul. Dachlast Leergewicht - vorn - hinten Nutzlast Zul. Gesamtgewicht - vorn - hinten * Fahrzeuge AM Serien- mässige JA ** Fahrzeuge AM Serien- mässige JA PA		TOWING ABILITY Trailer without brake Trailer with overrun brake Max. down thrust on towing ball Max. slope for starting Max. load on roof rack. Unladen weight of vehi- cle in running order - at the front - at the rear Load Total laden weight - at the front - at the rear * Véhicules AM standard JA ** Véhicules AM standard JA PA		CAPACIDAD DE REMOLQUE Remolque sin dispositivo de freno Remolque con freno de inercia Peso sobre el punto de enganche Pendiente máxima para arrancar con carga Peso máximo sobre porta- equipaje en el techo Peso del vehículo en orden de marcha - sobre parte delantera - sobre parte trasera Carga útil Peso total máximo autorizado en carga - sobre parte delantera - sobre parte trasera * Vehículos AM serie JA ** Vehículos AM serie JA PA		CAPACITA' DI TRAINO ----- Rimorchio con freno ad inerzia Peso sul gancio a sfera Partenza a carico su pendenza massima Peso massimo su porta- bagagli tetto Peso a vuoto, in ordine di marcia - sull'asse anteriore - sull'asse posteriore Carico utile Peso totale massimo autorizzato a carico - sull'asse anteriore - sull'asse posteriore * Veicoli AM serie JA ** Veicoli AM serie JA PA		250 Kg (550 lbs) 500 Kg (1100 lbs) 20 kg (44 lbs) 11 % (1 in 9) 30 Kg * ** (66 lbs) 725 kg 730 kg (1598 lbs) (1598 lbs) 435 kg (959 lbs) 290 kg 295 kg (6391 lbs) (650 lbs) 320 kg (705 lbs) 1050 kg (2314 lbs) 535 kg (1180 lbs) 540 kg (1190 lbs)		430 kg (948 lbs) 295 kg (650 lbs) 375 kg (826 lbs) 1100 kg (2424 lbs) 550 kg (1212 lbs) 600 kg (1322 lbs)			

1	MANUEL DE REPARATIONS REPARATURHANDBUCH REPAIR MANUAL MANUAL DE REPARACIONES MANUALE DI RIPARAZIONE	N° 559/1	OPERATIONS ARBEITSVORGÄNGE OPERATIONS OPERACIONES OPERAZIONI	AMB3 - 000	AMI 8 { BREAK COMMERCIAL (AM série JB) (ESTATE « COMMERCIAL ») BREAK SERVICE (AM série JC) (« SERVICE » VAN) }	9-1969
CARACTERISTIQUES GENERALES	ALLGEMEINE MERKMALE	GENERAL CHARACTERISTICS	CARACTERISTICAS GENERALES	CARATTERISTICHE GENERALI	BREAK COMMERCIAL AM série JB	BREAK SERVICE AM série JC
Désignation aux Mines	Technische Über- wachungsbezeichnung	Official symbol	Désignación en la dele- gación de industria	Denominazione di omologazione	AM série JB	AM série JC
Appellation commerciale	Handelsbezeichnung	Commercial symbol	Denominación comercial	Denominazione commerciale	BREAK COMMERCIAL	BREAK SERVICE
Symbole usine	Werksbezeichnung	Factory symbol	Símbolo de fábrica	Simbolo d'officina	AMC 3	AMU 3
Date de sortie	Ausstoss-Datum	Introduced	Fecha de salida	Data di uscita	9-1969	
Genre : VP	Type : PKW	Type : Private car	Tipo : VP	Tipo : Berlina	*	
Genre : Camionnette	Type : LKW	Type : Van	Tipo : Commercial	Tipo : Furgocino		
Puissance administrative	Steuer - PS	French fiscal rating	Potencia fiscal	Potenza fiscale	3 CV	
Nombre de places	Sitzplätze	Number of seats	Número de plazas	Numero posti	4/5	2/3
Empattement	Radstand	Wheelbase	Distancia entre ejes	Passo	2,400 m (7 ft 10 1/2 in)	
Voie avant	Spur, vorn	Track front	Ancho de vía delantera	Carreggiata ant.	1,260 m (4 ft 1 5/8 in)	
Voie arrière	Spur, hinten	Track rear	Ancho de vía trasera	Carreggiata post	1,220 m (4 ft 0 in)	
Longueur hors tout	Länge über alles	Length overall	Longitud máxima	Lunghezza massima	3,991 m (13 ft 1 1/8 in)	
Largeur hors tout	Breite über alles	Width overall	Anchura máxima	Larghezza massimo	1,524 m (5 ft 0 in)	

2	MANUEL DE REPARATIONS REPARATURHANDBUCH REPAIR MANUAL MANUAL DE REPARACIONES MANUALE DI RIPARAZIONE	OPERATIONS ARBEITSVORGÄNGE OPERATIONS OPERACIONES OPERAZIONI	AMI 8 { BREAK COMMERCIAL (AM série JB) BREAK SERVICE (AM série JC) } 9-1969			
CARACTERISTIQUES GENERALES (suite)	ALLGEMEINE MERKMALE (Forts.)	GENERAL CHARACTERISTICS (continued)	CARACTERISTICAS GENERALES (continuación)	CARATTERISTICHE GENERALI (seguito)	BREAK COMMERCIAL AM série JB	BREAK SERVICE AM série JC
Hauteur hors tout (à vide)	Höhe über alles	Height overall (unladen)	Altura máxima de carro- ceria (en vacío)	Altezza massima (a vuoto)	1,520 m (4 ft 11 3/4 in)	1,520 m (4 ft 11 3/4 in)
Garde au sol (en charge)	Bodenfreiheit ohne Belastung	Ground clearance (laden)	Distancia al suelo (en carga)	Distanza dal suolo (a carico)	0,130 m (5 1/8 in)	0,130 m (5 1/8 in)
Diamètre de braquage (environ)	Wendekreis - Ø (ungefähr)	Turning diameter (approx.)	Diámetro de giro (aprox.)	Diametro di sterzata (circa)	11,400 m (37 ft 4 in)	
DIMENSIONS INTERIEURES	INNERE ABMESSUNGEN	INSIDE DIMENSIONS	DIMENSIONS INTERIORES	DIMENSIONI INTERNE		
Longueur (à hauteur des dossiers)	Länge (in Höhe der Rückenlehne)	Length (at height of seat back)	Longitud (a altura del respaldo)	Lunghezza (all'altezza degli schienali)	2,450 m (8 ft 0 3/8 in)	2,450 m (8 ft 0 3/8 in)
Largeur (à hauteur des dossiers)	Breite (in Höhe der Rückenlehne)	Width (at height of seat back)	Anchura (a altura del respaldo)	Larghezza (all'altezza degli schienali)	1,340 m* (4 ft 4 3/4 in) 1,300 m** (4 ft 3 1/8 in)	1,340 m* (4 ft 4 3/4 in)
Hauteur	Höhe	Height	Alto	Altezza	1,110 m (3 ft 7 3/4 in)	1,110 m (3 ft 7 3/4 in)
* à l'avant ** à l'arrière	* Vorn ** Hinten	* at the front ** at the rear	* delantero ** trasero	* anteriore ** posteriore		

3	MANUEL DE REPARATIONS REPARATURHANDBUCH REPAIR MANUAL MANUAL DE REPARACIONES MANUALE DI RIPARAZIONE	N° 559/1	OPERATIONS ARBEITSVORGÄNGE OPERATIONS OPERACIONES OPERAZIONI	AMB3. 000	AMI 8 { BREAK COMMERCIAL (AM série JB) BREAK SERVICE (AM série JC) }	9-1969
CARACTERISTIQUES GENERALES (suite)	ALLGEMEINE MERKMALE (Forts.)	GENERAL CHARACTERISTICS (continued)	CARACTERISTICAS GENERALES (continuación)	CARATTERISTICHE GENERALI (seguito)	BREAK COMMERCIAL AM série JB	BREAK SERVICE AM série JC
CAPACITES DE REMORQUAGE Remorque sans dispositif de freinage Remorque avec frein à inertie Poids sur la rotule Pente maximum pour démarrage en charge Poids maxi sur galerie de toit Poids du véhicule car- rossé en ordre de marche - sur l'avant - sur l'arrière Charge utile Poids total maximum autorisé en charge - sur l'avant - sur l'arrière	ZULÄSSIGE ANHANGELASTEN Ungebrenst Gebremst Gewicht auf Kugelkopt Maxi. Steigung beim Anfahren unter voller Belastung Zul. Dachlast Leergewicht - Vorn - Hinten Nutzlast Zul. Gesamtgewicht - Vorn - Hinten	TOWING ABILITY Trailer without brake Trailer with overrun brake Max-down thrust on to- wing ball Max. slope for starting Max. load on roof rack Unladen weight of vehi- cle in running order at the front at the rear Load Total laden weight at the front at the rear	CAPACIDAD DE REMOLQUE Remolque sin dispositivo de freno Remolque con freno de inercia Peso sobre el punto de enganche Pendiente máxima para arrancar con carga completa Peso máximo sobre porta- equipage en el techo Peso del vehículo en orden de marcha sobre parte delantera sobre parte trasera Carga útil Peso total máximo autorizado en carga Sobre parte delantera Sobre parte trasera	CAPACITA' DI TRAINO Rimorchio con freno ad inerzia Peso sul gancio a sfera Partenza a carico su pendenza massima Peso massimo su porta- bagagli tetto Peso a vuoto, in ordine di marcia - sull'asse anteriore - sull'asse posteriore Carico utile Peso totale massimo autorizzato a carico - sull'asse anteriore - sull'asse posteriore	 250 kg (550 lbs) 500 kg (1100 lbs) 20 kg (44 lbs) 11% (1 in 9) 30 kg (66 lbs) 725 kg (1595 lbs) 430 kg (947 lbs) 295 kg (650 lbs) 375 kg (827 lbs) 1100 kg (2425 lbs) 550 kg (1212 lbs) 600 kg (1323 lbs)	 730 kg (1609 lbs) 430 kg (947 lbs) 300 kg (661 lbs) 370 kg (816 lbs)

CARACTERISTIQUES
GÉNÉRALES
(suite)

ALLGEMEINE
MERKMALE
(Forts)

GENERAL
CHARACTERISTICS
(continued)

CARACTERISTICAS
GÉNÉRALES
(continuación)

CARATTERISTICHE
GENERALI
(seguito)

- COTES PRINCIPALES - ALLGEMEINE ABMESSUNGEN - PRINCIPAL DIMENSIONS - COTAS PRINCIPALES - QUOTE PRINCIPALI -

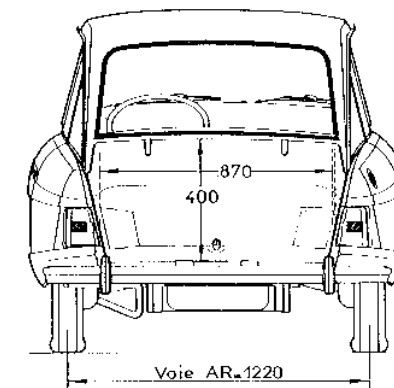
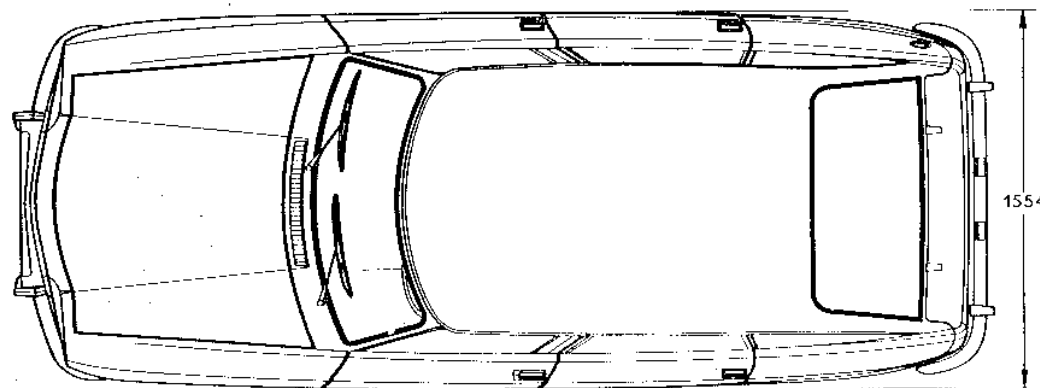
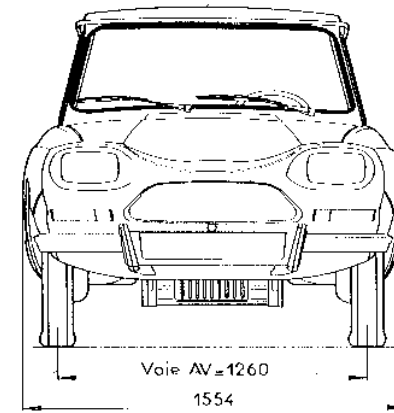
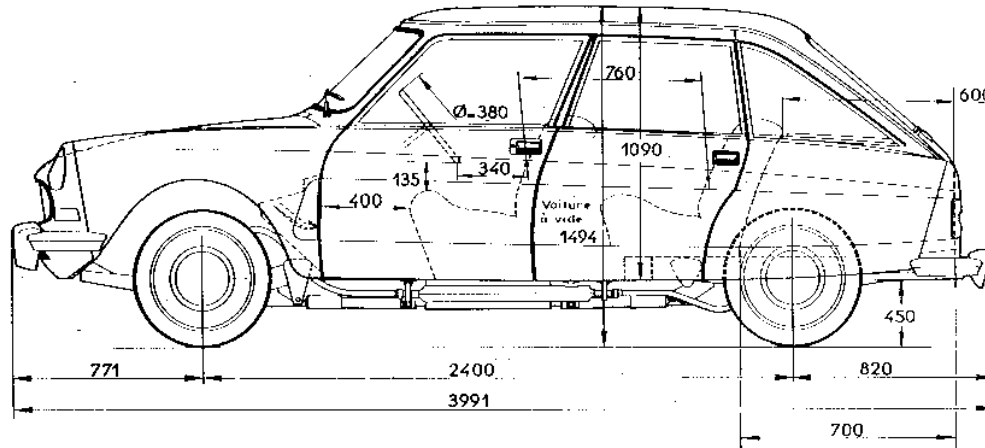

CARACTERISTIQUES
GÉNÉRALES
(suite)

ALLGEMEINE
MERKMALE
(Forts.)

GENERAL
CHARACTERISTICS
(continued)

CARACTERÍSTICAS
GÉNÉRALES
(continuación)

CARATTERISTICHE
GENERALI
(seguito)

AMB 3

COTES PRINCIPALES - ALLGEMEINE ABMESSUNGEN - PRINCIPAL DIMENSIONS - COTAS PRINCIPALES - QUOTE PRINCIPALI

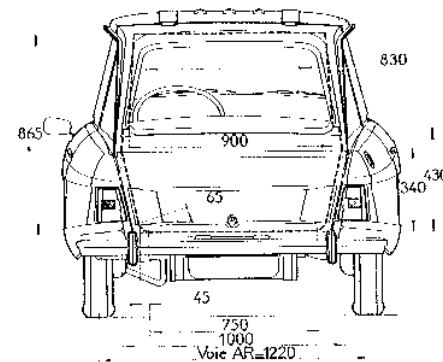
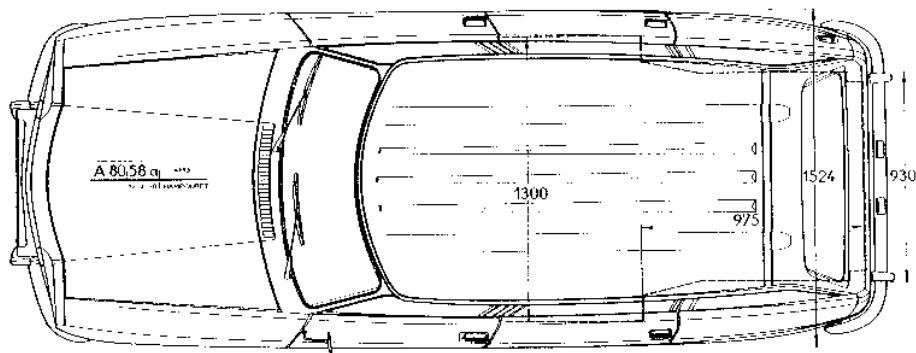
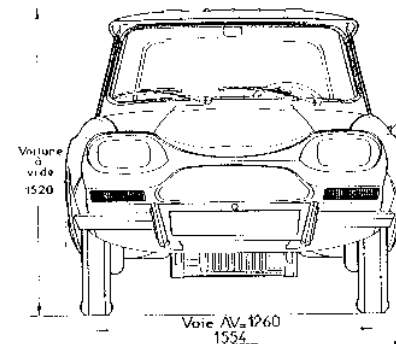
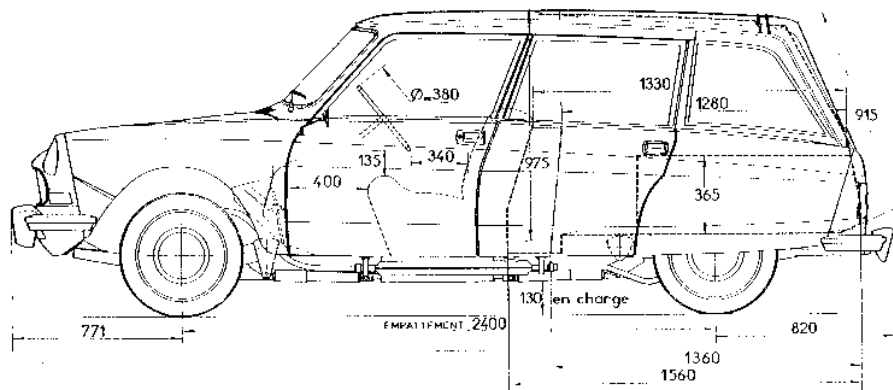

1 MANUEL DE REPARATIONS REPARATURHANDBUCH REPAIR MANUAL MANUAL DE REPARACIONES MANUALE DI RIPARAZIONE		N° 559	OPERATIONS ARBEITSVORGÄNGE OPERATIONS OPERACIONES OPERAZIONI		AM3 - 000	AMI 8 { BERLINE (AM serie JA) BREAK (AM serie JB) BREAK COMMERCIAL (AM serie JB) BREAK SERVICE (AM serie JC)	9-1969 →	MOTEUR - MOTOR - ENGINE - MOTOR - MOTORE M 28
CARACTERISTIQUES MOTEUR	MOTOR	ENGINE CHARACTERISTICS	CARACTERISTICAS DEL MOTOR	CARATTERISTICHE MOTORE				
Nombre de cylindres	Anzahl der Zylinder	Number of cylinders	Número de cilindros	Numero cilindri	2			
Alésage	Bohrung	Bore	Diámetro	Alesaggio	74 mm			
Course	Hub	Stroke	Carrera	Corsa	70 mm			
Cylindrée	Zylinderinhalt	Cubic capacity	Cilindrada	Cilindrata	602 cm ³			
Rapport volumétrique	Verdichtung	Ratio	Relación de compresión	Rapporto di compressione	9/1			
Puissance maxi.	Höchstleistung	Max. HP	Potencia máxima	Potenza massima	{ 35 Ch S.A.E. à 5750 tr/mn 32 Ch D.I.N. à 5750 tr/mn			
Couple maxi.	Max. Drehmoment	Max. torque	Par motor máximo	Coppia massima	4,7 mkg S.A.E. à 4750 tr/mn (33,9 ft lbs) 4,2 mkg D.I.N. à 4000 tr/mn (30,3 ft lbs)			
Ralenti	Leerlauf U/min	Idling speed	Ralenti	Minimo	750 ± 50 tr/mn 0			
DISTRIBUTION	VENTILSTEUERUNG	VALVE TIMING	DISTRIBUCION	DISTRIBUZIONE				
R.O.A	Einlass öffnet	Inlet valve opens A.T.D.C	Retraso apertura admisión R.A.A	R.A.A	0° 05'			
R.F.A	Einlass schliesst	Inlet valve closes A.B.D.C	Retraso cierre admisión R.C.A	R.C.A	49° 15'			
A.O.E	Auslass öffnet	Exhaust valve opens B.B.D.C	Avance apertura escape A.A.E	A.A.S	35° 55'			
R.F.E	Auslass schliesst	Exhaust valve closes A.T.D.C	Retraso cierre escape R.C.E	R.C.S	3° 30'			

2	MANUEL DE REPARATIONS REPARATURHANDBUCH REPAIR MANUAL MANUAL DE REPARACIONES MANUALE DI RIPARAZIONE	N° 559/1	OPERATIONS ARBEITSVORGÄNGE OPERATIONS OPERACIONES OPERAZIONI	AM3 - 000	AMI 8 <table style="display: inline-table; vertical-align: middle;"> <tr> <td style="font-size: 3em; vertical-align: middle;">}</td> <td> BERLINE (AM série JA) BREAK (AM série JB) BREAK COMMERCIAL (AM série JB) BREAK SERVICE (AM série JC) </td> <td style="font-size: 3em; vertical-align: middle;">}</td> </tr> </table>	}	BERLINE (AM série JA) BREAK (AM série JB) BREAK COMMERCIAL (AM série JB) BREAK SERVICE (AM série JC)	}	9-1969
}	BERLINE (AM série JA) BREAK (AM série JB) BREAK COMMERCIAL (AM série JB) BREAK SERVICE (AM série JC)	}							
MOTEUR - MOTOR - ENGINE - MOTOR - MOTORE : M28									

CARACTERISTIQUES MOTEUR (suite)	MOTOR (Forts.)	ENGINE CHARACTERISTICS (continued)	CARACTERISTICAS DEL MOTOR (continuación)	CARATTERISTICHE MOTORE (seguito)	
Jeux théoriques aux soupapes : - admission - échappement	Prüfung der Steuerzeiten : - Einlass - Auslass	Théorétical valve clearance : - inlet - exhaust	Juego teórico de las válvulas : - admisión - escape	Gioco teorico delle valvole : - aspirazione - scarico	1 mm (0,039") 1 mm (0,039")
Jeux pratiques aux culbuteurs : <u>A froid</u> - admission - échappement	Ventilspiel : <u>Kalt</u> - Einlass - Auslass	Valve rocker clearances : <u>Cold</u> - inlet - exhaust	Juego practico de las balancines : <u>En frío</u> - admisión - escape	Gioco pratico dei bilancieri : <u>A freddo</u> - aspirazione - scarico	0,15 mm (0,006") 0,15 mm (0,006")
Régler une soupape lorsque la soupape correspondante du cylindre opposé est ouverte au maximum.	Einstellen, wenn des entsprechende Ventil des entgegengesetzten Zylinders voll geöffnet ist.	Adjust one valve when the corresponding valve on the opposite cylinder is fully open.	Regular una válvula cuando la válvula correspondiente del cilindro opuesto está abierta al máximo.	Regolare una valvola quando la valvola corrispondente del cilindro opposto è aperta al massimo.	

4	MANUEL DE REPARATIONS REPARATURHANDBUCH REPAIR MANUAL MANUAL DE REPARACIONES MANUALE DI RIPARAZIONE	N° 559/1	OPERATIONS ARBEITSVORGÄNGE OPERATIONS OPERACIONES OPERAZIONI	AM3. 000	AMI 8	BERLINE (AM série JA) BREAK (AM série JB) BREAK COMMERCIAL (AM série JB) BREAK SERVICE (AM série JC) 9 - 1969 
CARACTERISTIQUES MOTEUR (suite)	MOTOR (Forts.)	ENGINE CHARACTERISTICS (continued)	CARACTERISTICAS DEL MOTOR (continuación)	CARATTERISTICHE MOTORE (seguito)		
ALLUMAGE	ZÜNDUNG	IGNITION	ENCENDIDO	ACCENSIONE		
Bobine	Zündspule	Coil	Bobina	Bobina	DUCELLIER 4009	
Allumeur	Verteiler	Contact breaker	Distribuidor de encendido	Spinterogeno	DUCELLIER 605774	
Point d'allumage 8° avant P.M.H	Zündzeitpunkt 8° var. O.T.	Static advance 8° B.T.D.C	Punto de encendido 8° antes P.M.S	Punto d'accensione 8° dopo il P.M.S		
Bougies	Zündkerzen	Plugs	Bujías	Candele	S.E.V.Marchal 34 S-AC 42 FF	
GRAISSAGE	SCHMIERUNG	LUBRICATION	LUBRICACION	LUBRIFICAZIONE		
Huile moteur	Motoröl	Engine oil	Aceite motor	Olio motore	TOTAL Altigrade GT. spéciale autoroute 20W 40	
Contenance du carter - apres vidange - apres demontage des couver-culasses - entre mini et maxi	Fassungsvermögen normal - Nach Ölwechsel - Nach Abbau der - Zylinderkopfdeckel - Zwischen mini-maxi	Sump capacity - after draining - afterremoving cyl. head cover. - between min and maxi	Capacidad del carter - despues del vaciado - despues del desmontaje de las tapas de culata - entre mínimo y máximo	Capacita' del carter - per sostituzione - dopo smontaggio dei coperchi testata - tra minimo e massimo	2,2 L (3 1/2 pts Imp) 2,5 L (4.4 pts Imp) 0,5 L (7/8 pt Imp)	
Pression d'huile (huile a 80°C)	Öldruck (Öl bei 80°C)	Oil pressure (oil at 80°C)	Presión de aceite (aceite a 80°C)	Pressione olio motore (olio a 80°C)	5,5 à 6,5 kg/cm2 à 6000 tr/mn (79 to 93 PSI at 6000 rpm)	
Filtre a huile (à tamis dans carter)	Ölfilter (Siebfilter im Gehäuse)	Oil filter (gauze in sump)	Filtro de aceite (Tamiz en el cárter)	Filtro olio (a reticella nel carter)		
REFROIDISSEMENT	KÜHLUNG	COOLING	REFRIGERACION	RAFFREDDAMENTO		
par air pulsé	durch Luftgebläse	air, fan - blown	por aire pulsado	ad aria forzata		

COUPE HORIZONTALE

DRAUFSICHT

HORIZONTAL SECTION

SECCION HORIZONTAL

SEZIONE ORIZZONTALE

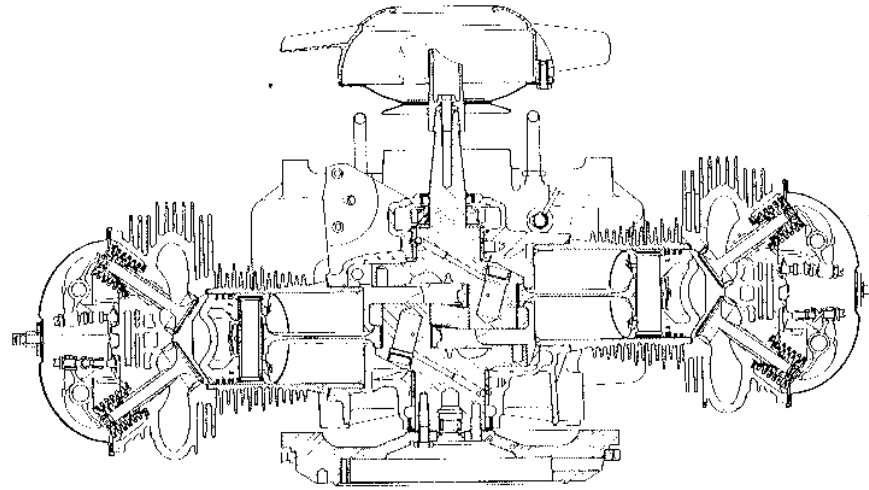

A. 10-2

COUPE TRANSVERSALE

QUERSCHNITT

CROSS SECTION

SECCION TRANSVERSAL

SEZIONE TRASVERSALE

17-11-1969 →

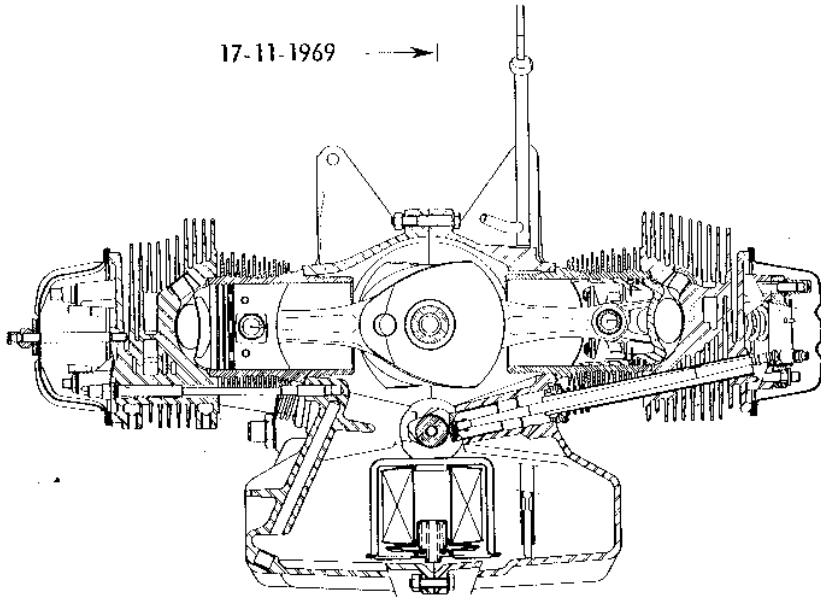

A. 10-6

A. 10-6 a

17-11-1969 →

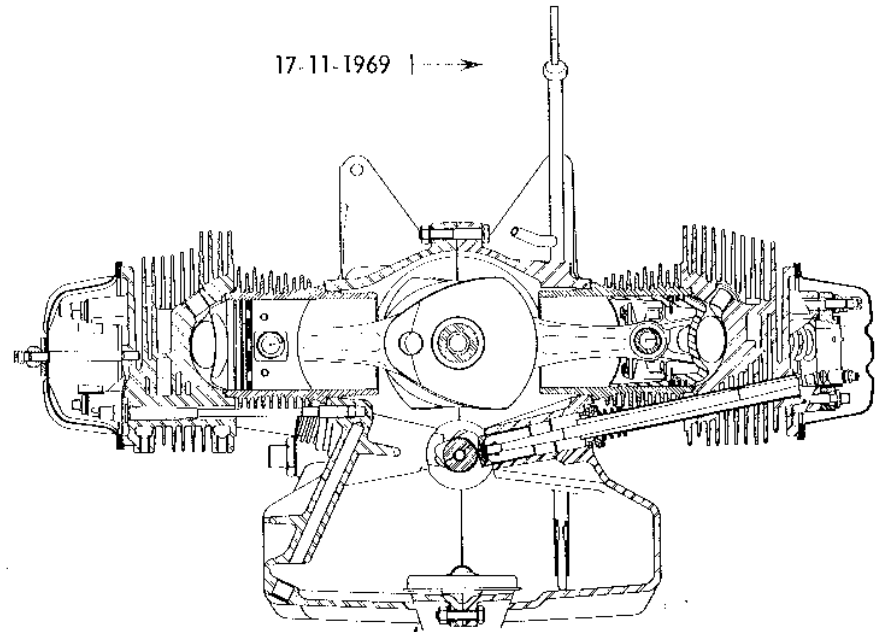

CARTER MOTEUR

Carter avec fixation de la pompe à essence à gauche-

Les 4 bossages d'appui du carter moteur sur un même plan

DISTANCES

↓ Axe de vilebrequin
↓ Pieds de centrage

↓ Axe de vilebrequin
↓ Goujons
- Identiques

ASSEMBLAGE DES 1/2
CARTERS
SERRAGE :

Boulons d'assemblage

Ecrous des goujons

Ecrous des goujons

MOTORGEHÄUSE

Motorgehäuse mit Benzin-
pumpenbefestigung links

Die 4 Auflagepunkte
müssen auf einer Ebene
liegen, zulässige Tole-
ranz maxi

ABSTAND

↓ Kurbelwelle
↓ Zentrierstifte

↓ Kurbelwelle
↓ Stehbolzen
- Gleich max. Toleranz

VERBINDUNG DER
GEHÄUSEHÄLFTEN
ANZUGSMOMENT :

Anschlussbolzen

Stehbolzenmutter

Stehbolzenmutter

CRANKCASE

Crankcase with left hand
pétrol pump mounting

The 4 crankcase bosses
are in the same plane
to within

CENTRE - DISTANCES

↓ Crankpin
↓ Dowels

↓ Crankpin
↓ Studs
- Identical-to within

ASSEMBLY OF CRANK-
CASE HALVES
TIGHTENING :

Assembly bolts

Nuts on assembly studs

Nuts on assembly studs

CARTER MOTOR

Cárter con fijación de la
bomba de gasolina a
izquierda

Los 4 abultamientos de
apoyo del cárter motor
en un mismo plano

DISTANCIAS

↓ Eje de cigüeñal
↓ Pies de centrage

↓ Eje del cigüeñal
↓ Espárragos
- Idénticos-

ACOPLAMIENTO DE
LOS 1/2 CARTERES
APRIETE :

Tornillos de acoplamiento

Tuercas de espárragos
de acoplamiento

Tuercas de espárragos
de acoplamiento

CARTER MOTORE

Carter con fissaggio
pompa benzina a
sinistra

I 4 rilievi d'appoggio
carter motore sono sullo
stesso piano

DISTANZE

↓ Asse albero motore
↓ Grani di centraggio

↓ Asse albero motore
↓ Prigionieri
- Identici

ASSEMBLAGGIO DEI 1/2
CARTER
SERRAGGIO :

Viti d'assemblaggio

Dadi dei prigionieri
d'assemblaggio

Dadi dei prigionieri
d'assemblaggio

à 0,10 mm près
(aproxima)
à 0,10 mm
(circa)

à 0,10 mm près
(aproxima)
à 0,10 mm
(circa)

$\phi = 7 \text{ mm} - 1,9 \text{ mkg}$ | 14 ft lbs

$\phi = 7 \text{ mm} - 1,9 \text{ mkg}$ | 14 ft lbs

$\phi = 10 \text{ mm} - 4,5 \text{ mkg}$ | 33 ft lbs

<p>MANUEL DE REPARATIONS REPARATURHANDBUCH REPAIR MANUAL MANUAL DE REPARACIONES MANUALE DI RIPARAZIONE</p>	<p>OPERATIONS ARBEITSVORGÄNGE OPERATIONS OPERACIONES OPERAZIONI</p>	<p>AMI 8</p> <p>BERLINE (AM serie JA) BREAK (AM serie JB) BREAK COMMERCIAL (AM serie JB) BREAK SERVICE (AM serie JC)</p> <p>9-1969</p>
--	---	--

<p>CULASSE</p> <p>SIEGES DE SOUPAPES Largeur de la portée admission et échappement</p> <p>GUIDES DE SOUPAPES Alésage { Admission (en bronze) Echappement }</p> <p>ECROUS DE FIXATION DE CULASSES REMARQUE IMPORTANTE</p> <p>Le serrage définitif des culasses ne se fait qu'après la pose et le serrage des tubulures d'admission et d'échappement</p> <ul style="list-style-type: none"> - Serrer progressivement dans l'ordre suivant : - écrou supérieur avant - écrou supérieur arrière - écrou inférieur <p>1er serrage 2è serrage</p>	<p>ZYLINDERKOPF</p> <p>VENTILSITZ Breite der Sitze Einlass-Auslass</p> <p>VENTILFÜHRUNGEN Bohrung { Einlass (IN BRONZE) Auslass =↑ }</p> <p>ZYLINDERKOPFSCHRAUBEN ACHTUNG:</p> <p>Das Festziehen der Zylinderkopfschrauben darf erst nach endgültiger Montage des Ansaugkrümmers geschehen</p> <ul style="list-style-type: none"> - Progressiv in folgender Reihenfolge festziehen : - vordere, obere Mutter - hintere, obere Mutter - untere Mutter <p>1 - Anziehen 2 - Festziehen</p>	<p>CYLINDER HEAD</p> <p>VALVE SEATS Width of face inlet and exhaust</p> <p>VALVE GUIDES Bore { Inlet = ↓ (IN BRONZE) Exhaust = ↑ }</p> <p>CYLINDER HEAD SECURING NUTS IMPORTANT NOTE:</p> <p>The final tightening of the cylinder heads must be done only after tightening the inlet and exhaust manifolds</p> <ul style="list-style-type: none"> - Tighten progressively in the following order : - upper front nut. - upper rear nut. - lower nut <p>1 st tightening 2 nd tightening</p>	<p>CULATA</p> <p>ASIENTOS DE VALVULAS Ancho del asiento admisión y escape</p> <p>GUIAS DE VALVULAS Diámetro { Admisión = ↓ (DE BRONCE) Escape = ↑ }</p> <p>TUERCAS DE FIJACION DE CULATAS OBSERVACION IMPORTANTE:</p> <p>El apriete definitivo de las culatas se hace una vez puestas y apretados los colectores de admisión y escape</p> <ul style="list-style-type: none"> - Apretar progresivamente en el orden siguiente : - tuerca superior delantera - tuerca superior trasera - tuerca inferior <p>1º apriete 2º apriete</p>	<p>TESTATA</p> <p>SEDI VALVOLE Larghezza della portata aspirazione e scarico</p> <p>GUIDAVALVOLE Alesaggio { Aspirazione = ↓ (IN BRONZO) Scarico = ↑ }</p> <p>DADI DI FISSAGGIO TESTATE OSSERVAZIONE IMPORTANTE</p> <p>Il serraggio definitivo delle testate va eseguito dopo riattacco e serraggio dei collettori di aspirazione e scarico</p> <ul style="list-style-type: none"> - Serrare progressivamente nell'ordine seguente : - dado superiore anteriore - dado superiore posteriore - dado inferiore <p>1º serraggio 2º serraggio</p>	<p>* 1,45 mm maxi</p> <p>** 1,80 mm maxi</p> <p>+ 0,020 8 + 0,005 mm</p> <p>+ 0,005 8,5 - 0,010 mm</p> <p>0,2 à 0,4 mkg (1.45 to 2.89 ft lbs) 2 à 2,3 mkg (14 1/2 To 17 ft lbs)</p>
--	--	---	--	--	---

* Admission Einlass Inlet Admisión Aspirazione	** Echappement Auslass Exhaust Escape Scarico
--	---

ADMISSION
EINLASS
INLET
ADMISION
ASPIRAZIONE

A.11.4

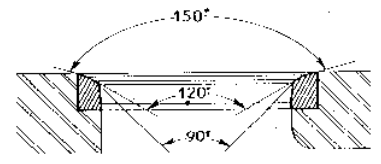

ECHAPPEMENT
AUSLASS
EXHAUST
ESCAPE
SCARICO

A.11.4

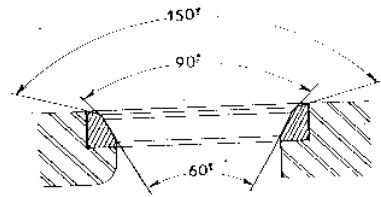

2	VILEBREQUIN (suite)	KURBELWELLE (Forts.)	CRANKSHAFT (continued)	CIGÜEÑAL (continuación)	ALBERO MOTORE (seguito)	
	Retrait de la douille à aiguilles de centrage d'arbre de commande par rapport à la face arrière du vilebrequin	Rückstand des Nadellagers zur Zentrierung der Pleuelwelle im Verhältnis zur hinter Fläche an der Pleuelwelle	Inset of needle roller cage centring dowel of main shaft relation to rear face of crankshaft	Retracción del cojinete de agujas de centrado del eje de mando con relación a la cara trasera del cigüeñal	Rientranza della boccola a rullini di centroggio albero di comando rispetto alla faccia post. dell'albero motore	5 mm
	<p align="center">BIELLES</p> <ul style="list-style-type: none"> - Jeu latéral des bielles (non démontables) - Alésage des bagues de pied de bielles - Alésage des bagues vendues par le Service des Pièces de Rechange - Jeu maxi de l'axe de piston - Différence de poids sur un même attelage 	<p align="center">PLEUEL</p> <p>Seitenspiel (nicht demontierbar) Bohrung der Pleuelbüchse</p> <p>Buchsen beim ET, erhältlich, Bohrung ca</p> <p>Maximalspiel des Pleuelbolzens. Unterschied der Gewichte zum Ausgleich der Unwucht</p>	<p align="center">CONNECTING RODS</p> <p>End float of connecting rods (not capable of dismantling) Bore of small end bushes</p> <p>Bore of bushes sold by our Spare Parts Dept.</p> <p>Maximum clearance on gudgeon pin Difference in weight on the same set of rods</p>	<p align="center">BIELAS</p> <p>Juego lateral de las bielas (no desmontables) Diámetro de los casquillos de pie de biela Diámetro de los casquillos vendidos por el servicio de recambios Juego máxi. del eje de pistón Diferencia de peso en un mismo equipo motor</p>	<p align="center">BIELLE</p> <p>Gioco assiale delle bielle (non smontabili) Alesaggio delle boccole del piede di biella Alesaggio delle boccole fornite dal Servizio Ricambi Gioco massimo dello spinotto Differenza di peso su uno stesso accoppiamento</p>	<p align="center">0,08 à 0,13 mm</p> <p align="center">20,005 $\begin{matrix} + 0,011 \\ + 0,006 \end{matrix}$ mm</p> <p align="center">19,950 mm</p> <p align="center">0,018 mm</p> <p align="center">2,5 g maxi</p>

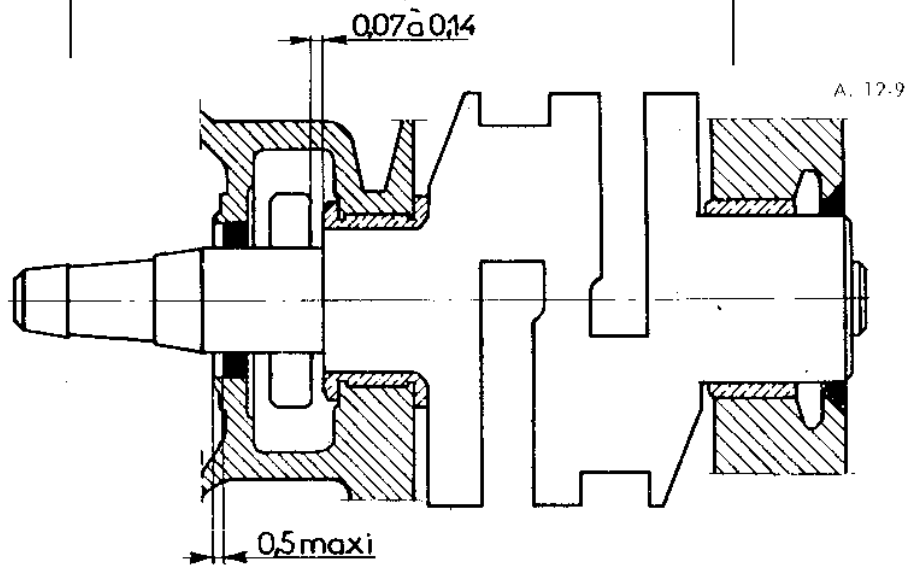

1	MANUEL DE REPARATIONS REPARATURHANDBUCH REPAIR MANUAL MANUAL DE REPARACIONES MANUALE DI RIPARAZIONE	} N° 559/1	OPERATIONS ARBEITSVORGÄNGE OPERATIONS OPERACIONES OPERAZIONI	} AM3. 100 - 3	} AMI 8	} BERLINE (AM série JA) BREAK (AM série JB) BREAK COMMERCIAL (AM série JB) BREAK SERVICE (AM série JC) 9 - 1969 ⇌
VILEBREQUIN Aucune rectification possible Jeu latéral du vilebrequin (non réglable) Bague d'étanchéité de palier arrière Bague d'étanchéité de palier avant : retrait par rapport au carter Épaisseur de la bague d'étanchéité en bout de vilebrequin : - montage avec douille à aiguilles - montage avec bague auto-lubrifiante	KURBELWELLE Nachschleifen nicht möglich Seitenspiel der Kurbelwelle (nicht einstellbar) Dichtring des hinteren Lagers Dichtring des vorderen Lagers : Rückstand im Verhältnis zum Gehäuse Stärke des Dichtringes am Kurbelwellenende - Einbau mit Nadellagerbüchse - Einbau mit Selbstschmierbüchse	CRANKSHAFT No grinding possible End float of crankshaft (not adjustable) Sealing bush of rear bearing Sealing bush for front bearing : inset with relation to crankcase Thickness of seal at end of crankshaft : - needle - roller type - self lubricating bush type	CIGÜENAL Ninguna rectificación posible Juego lateral del cigüeñal (no regulable) Retén de estanqueidad del cojinete trasero Retén de estanqueidad del cojinete delantero : retracción con relación al cárter Espesor del reten de estanqueidad en el terminal del cigüeñal : - montaje con cojinete de agujas. - montaje con casquillo auto-lubrificante	ALBERO MOTORE Nessuna rettifica possibile Gioco assiale dell'albero motore (non regolabile) Boccola di tenuta del supporto post. Boccola di tenuta del supporto ant : rientrante rispetto al carter Spessore della boccola di tenuta in testa all'albero motore : - montaggio con boccola a rullini - montaggio con boccola autolubrificante	0,07 à 0,14 mm - Collet de la bague au contact du chanfrein du carter - Dichtring in Abfassung des Gehäuses ankleben - Collar of bush in contact with chamfer on crankcase - Pestaña del reten en contacto con el chaflán del carter - Colletto della boccola a contatto dello smusso del carter } 0,5 mm MAXI } 3 mm } 5 mm	

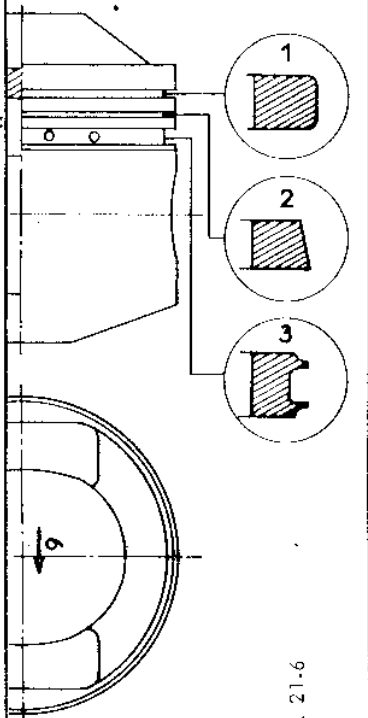
4	PISTONS	KOLBEN	PISTONS	PISTONES	PISTONI	
	Repère sur piston Sens de montage : Flèche vers l'avant du véhicule ; 9 indique le rapport volumétrique	Markierung am Kolben Einbaurichtung : Pfeil nach vorn in Fahr- richtung ; 9 zeigt die Verdichtung an	Mark on piston Fitting method : Arrow towards the front of the vehicle 9 indicates the compression ratio.	Punto de referencia sobre el pistón Sentido de montaje : Flecha hacia adelante del vehículo ; 9 indica la rela- ción volumétrica	Riferimento sul pistone Senso di montaggio : Freccia verso la parte ante- riore del veicolo ; 9 indica il rapporto di compressione	$\frac{AV}{9}$
	AXE DE PISTON $\left\{ \begin{array}{l} L = \\ \phi = \end{array} \right.$	KOLBENBOLZEN $\left\{ \begin{array}{l} L = \\ \phi = \end{array} \right.$	GUDGEON, PIN $\left\{ \begin{array}{l} L = \\ \phi = \end{array} \right.$	EJE DE PISTÓN $\left\{ \begin{array}{l} L = \\ \phi = \end{array} \right.$	SPINOTTO $\left\{ \begin{array}{l} L = \\ \phi = \end{array} \right.$	$63,9 \begin{array}{l} - 0,1 \\ - 0,3 \end{array} \text{ mm}$ $20 \pm 0,002 \text{ mm}$
	SEGMENTS	KOLBENRINGE	PISTON RINGS	SEGMENTOS	SEGMENTI	
	Le repère sur la partie su- perieure des segments, in- dique : 1° Le sens du montage Repère vers la partie supé- rieure du piston 2° La marque du fournis- seur Surépaisseur admise 0,005 mm Tierçage des segments : orienter les coupes à 120°	Die Markierung am oberen Teil der Kolbenringe zeigt an : 1° Die Einbaurichtung : Markierung zum oberen Teil des Kolbens 2° Die Herstellerfirma Zulässiges Übermass 0,005 mm Einbau der Kolbenringe um 120° versetzt	The mark on the upper part of the ring indicates : 1 St - The method of fitting The mark towards the upper part of the piston 2 nd - The manufacturer's mark Allowable oversize on thi- ckness 0,005 mm Positioning the ring gaps : arrange the gaps at 120°	El punto de referencia en la parte superior de los segmentos, indica : 1° El sentido del montaje : Punto de referencia hacia la parte superior del pistón 2° La marca del proveedor Sobreespesor admitido 0,005 mm Montaje de los segmentos orientar los cortes a 120°	Il riferimento sulla parte superiore dei segmenti indica : 1° Il senso di montaggio: riferimento verso la parte superiore del pistone 2° La marca del fornitore Sovrappessore ammesso 0,005 mm Orientamento dei segmenti : disporre i tagli a 120°	

3	MANUEL DE REPARATIONS REPARATURHANDBUCH REPAIR MANUAL MANUAL DE REPARACIONES MANUALE DI RIPARAZIONE	N° 559/1	OPERATIONS ARBEITSVORGÄNGE OPERATIONS OPERACIONES OPERAZIONI	AM3. 111 - 4	AMI 8	BERLINE (AM série JA) BREAK (AM série JB) BREAK COMMERCIAL (AM série JB) BREAK SERVICE (AM série JC) 9 - 1969
---	---	----------	--	--------------	-------	---

PISTONS ET SEGMENTS	KOLBEN UND KOLBENRINGE	PISTONS AND PISTON RINGS	PISTONES Y SEGMENTOS	PISTONI E SEGMENTI
---------------------	------------------------	--------------------------	----------------------	--------------------

	PISTONS KOLBEN PISTONS	PISTONES PISTONI	SEGMENTS - KOLBENRINGE - RINGS - SEGMENTOS - SEGMENTI			
	LARGEUR DE LA GORGE BREITE DER NUT WIDTH OF GROOVE ANCHURA DE LA RANURA LARGHEZZA DELLA GOLA	REPFRE MARKIERUNG MARK SEÑAL RIFERIMENTO	NOMBRE ANZ. NUMBER NÚMERO NUMERO	EPAISSEUR STÄRKE THICKNESS ESPESSOR SPESSORE	JEU A LA COUPE SPIEL CLEARANCE AT GAP JUEGO EN EL CORTE GIOCO AL TAGLIO	
ETANCHEITE KOMPRESSIÖNSRING COMPRESSION RING ESTANQUEIDAD TENUTA	1,5 + 0,040 mm + 0,020	1	1	1,5 - 0,010 mm - 0,025	0,20 à 0,35 mm	
RACLEUR ABSTREIFRING SCRAPER RING RASCADOR RASCHIAOLIO	2 + 0,040 mm + 0,020	2	1	2 - 0,010 mm - 0,025	0,20 à 0,35 mm	
REFOULEUR ABWEISSRING OIL CONTROL RING ENGRASE COMPRESIONE	4 + 0,030 mm + 0,010	3	1	4 - 0,010 mm - 0,022	0,15 à 0,30 mm	

5	MANUEL DE REPARATIONS REPARATURHANDBUCH REPAIR MANUAL MANUAL DE REPARACIONES MANUALE DI RIPARAZIONE	OPERATIONS ARBEITSVORGÄNGE OPERATIONS OPERACIONES AM3. 120 - 0	AMI 8 BERLINE (AM série JA) BREAK (AM série JB) BREAK COMMERCIAL (AM série JB) BREAK SERVICE (AM série JC) 9 - 1969		
DISTRIBUTION ARBRE A CAMES En fonte (repère 42 entre 2e et 3e came) Jeu latéral (non réglable) Levée de cames Variation sur une came (par rapport à l'axe de la pièce)	VENTILSTEUERUNG NOCKENWELLE Aus Guss (Markierung 42 zwischen 2. und 3. Nocke) Seitenspiel (nicht einstellbar) Nockenabstand Toleranz der Nockenhöhe (im Verhältnis zur Mittelachse der Welle)	VALVE TIMING CAMSHAFT Cast (marked 42 between 2 nd and 3 rd cam) End float (not adjustable) Cam lift Variations on cam (in relation to centre line)	DISTRIBUCION ARBOL DE LEVAS Fundido (marca de referencia 42 entre 2a y 3a leva) Juego lateral (no regulable) Levantamiento de leva Variación sobre una leva (con relación al eje de la pieza)	DISTRIBUZIONE ALBERO DISTRIBUTORE In ghisa (riferimento 42 tra 2a 3a camma) Gioco assiale (non regolabile) Alzata della camma Variazione su una camma (rispetto all'asse dell'albero)	 0,04 à 0,09 mm 6,237 ± 0,02 mm 0,02 mm maxi
POMPE A HUILE Jeu latéral des pignons	ÖLPUMPE Seitenspiel der Zahnräder	OIL PUMP End float of pinions	BOMBA DE ACEITE Juego lateral de los piñones	POMPA DELL'OLIO Gioco assiale degli ingranaggi	0,02 à 0,10 mm
POUSSOIRS Diamètre nominal Longueur =	STÖSSELBECHER Durchmesser Länge =	TAPPETS Nominal diameter Length =	EMPUJADORES Diámetro nominal = Longitud =	PUNTERIA Diametro nominale Lunghezza =	24 mm 42 ± 1 mm
TIGE DE CULBUTEUR Longueur Flèche maxi. au diamètre le plus fort	STÖSSELSTANGEN Länge Maximaler Schlag am grössten Durchmesser	PUSH RODS Length Maximum out of straight on largest diameter	VARILLA BALANCIN Longitud Flecha máxima al diámetro más fuerte	ASTA DEL BILANCIERE Lunghezza Freccia massima sul diametro maggiore	286,3 $\begin{matrix} +0,4 \\ -1 \end{matrix}$ mm 0,2 mm maxi

4 bis

REMARQUE : Depuis décembre 1969, un nouveau segment racléur dit «à queue d'aigle» est monté sur tous les moteurs. Il est recommandé de monter ce nouveau segment en cas de remise en état d'un moteur

ATTENTION

Les trois segments sont repérés près de la coupe par la lettre «H» ou l'indication «TOP» ou «Haut» ou le nom du fournisseur.

Ex: NOVA.

Cette indication doit être orientée vers le haut du piston

ANM. : Ab Dezember 1969 wird ein neuer Abstreifring ein sogenanter "Alderschwanz" bei allen Motoren eingebaut. Es wird empfohlen, diesen neuer Abstreifring beim Überholendes Motors einzubauen.

ACHTUNG

Die drei Sicherungsringe sind in der Nähe ihres Schnitts durch den Buchstaben "H" oder die Aufschrift "TOP" oder "Haut" oder eden Namen des Lieferanten gekennzeichnet
Beispiel : NOVA.

Diese Markierung muss zur Kolbenoberseite gerichtet werden

NOTE : Since December 1969 a new oil scraperring konwn as "Eagles Tail" is fitted on all engines. It is recommended to fit this new ring when an engine is being rebuilt

NOTE

The tree piston rings are marked near their gap, with the letter "H" or the word "TOP" or "Haut" or the name of the manufacturer
eg : NOVA.

This marking must always be fitted towards the upper part of the piston

OBSERVATION : A partir de diciembre de 1969, un nuevo tipo de segmento rascador llamado "de cola milano" se monta sobre todos los motores. Se recomienda de montar este nuevo tipo de segmento en caso de una reparación de motor

ATENCION

Los tres segmentos están marcados cerca de las puntas con la letra "H" o la indicación "TOP" o "Haut" o el nombre del proveedor.
Ej. : NOVA.

Esta indicación debe ser orientada hacia la parte alta del pistón

IMPORTANTE : Da dicembre 1969, un nuovo segmento raschialio detto "a coda d'aquila" è montato su tutti i motori. Si raccomanda di montare questo nuovo segmento in caso di revisione motore

ATTENZIONE

I tre segmenti sono segnati, in prossimità del taglio, dalla lettera "H" o dall' indicazione "TOP" o "Haut" od il nome del fornitore
Es. : NOVA.

Questa indicazione deve essere orientata verso la testa del pistone

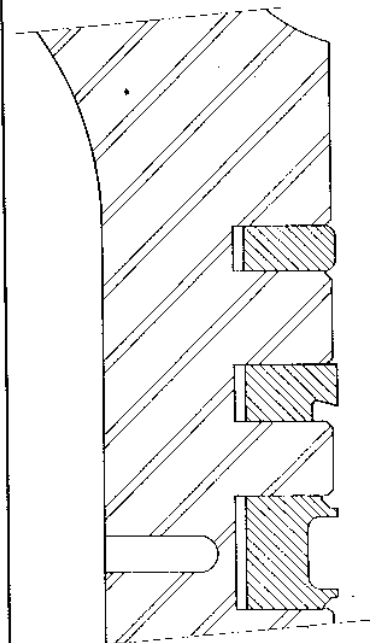

A12-50a

7	MANUEL DE REPARATIONS REPARATURHANDBUCH REPAIR MANUAL MANUAL DE REPARACIONES MANUALE DI RIPARAZIONE	N° 559/1	OPERATIONS ARBEITSVORGÄNGE OPERATIONS OPERACIONES OPERAZIONI	AM3. 100 - 00 AM3. 112 - 3 AM3. 120 - 0	AMI 8	BERLINE (AM série JA) BREAK (AM série JB) BREAK COMMERCIAL (AM série JB) BREAK SERVICE (AM série JC) 9 - 1969
---	--	----------	---	---	-------	---

JEUX DES CULBUTEURS	VENTILSPIELE	VALVE ROCKER CLEARANCES	JUEGOS DE LOS BALANCINES	GIOCO DEI BILANCIERI	
JEUX THEORIQUES : (Pour vérification de la distribution) - admission - échappement	VENTILSPIEL THEORETISCH : (Zur Prüfung der Steuerzeit) -- Einlass - Auslass	THEORETICAL CLEARANCE : (For checking the timing) - inlet - exhaust	JUEGOS TEORICOS : (Para verificación de la distribución) - admisión - escape	GIOCO TEORICO : (Per verifica della distribuzione) - aspirazione - scarico	1 mm (0,040") 1 mm (0,040")
JEUX PRATIQUES : (à froid) - admission - échappement Régler une soupape lorsque la soupape correspondante du cylindre opposé est ouverte	VENTILSPIEL PRAKTISCH : (Kalt) - Einlass - Auslass Ein Ventil einstellen, wenn das gleiche Ventil des entgegengesetzten Zylinders voll geöffnet ist.	RUNNING CLEARANCE : (engine cold) - inlet - exhaust Adjust one valve when the corresponding valve of the opposite cylinder is fully open	JUEGOS PRACTICOS : (en frío) - admisión - escape Hacer el reglaje de una válvula cuando la válvula correspondiente del cilindro opuesto está abierta	GIOCO PRATICO : (a freddo) - aspirazione - scarico Regolare una valvola quando la valvola corrispondente del cilindro opposto è aperta.	0,15 mm 0,15 mm (0,006")
VERIFICATION DU CALAGE Moteur froid - Donner au culbuteur échappement un jeu de : (Soupape admission ouverte au maximum) - Contrôler ce jeu au point d'allumage (pige ϕ 6 dans son logement) en faisant tourner le moteur dans le sens inverse de marche Jeu à obtenir :	VENTILSTEUERUNGS-KONTROLLE Motor kalt - Spiel am Kipphebel des Auslassventils : (Einlassventil ganz geöffnet) - Zündzeitpunkt mit Hilfe des 6 mm - Stiftes zwischen Gehäuse und Schwungrad festlegen - Motor entgegen der Laufrichtung zurückdrehen. Ventilspiel beträgt dann :	CHECKING THE SETTING Engine cold - Give the exhaust rocker a clearance of : (with the inlet valve fully open) - Check this clearance at the ignition static setting position (6 mm DIA. pin in position) by turning the engine back Clearance to be :	COMPROBACION DEL CALADO Motor frío - Dejar al balancín de escape un juego de : (válvula admisión abierta al máximo) - Comprobar ese juego en el punto de encendido (calibre ϕ 6 en su alojamiento) haciendo girar el motor en sentido inverso de la marcha Juego a obtener :	VERIFICA DELLA FASATURA Motore freddo - Dare al bilanciere di scarico un gioco di : (valvola d'aspirazione aperta al massimo) - Controllare il gioco al punto d'accensione (spina ϕ 6 nel suo alloggiamento) facendo ruotare il motore inversamente al senso di marcia. Gioco da realizzare :	2 mm (0,080") 0,03 à 0,75 mm

6	CULBUTEURS	KIPPHEBEL	ROCKERS	BALANCINES	BILANCIERI	
Axe	Diamètre Entr'axe des trous de fixation	Achse Durchmesser Abstand der Befestigungsbohrungen	Spindle Diameter Centres of fixing holes	Eje Diámetro Entre ejes de los orificios de fijación	Perno Diametro Interasse dei fori di fissaggio	$14 \begin{smallmatrix} 0 \\ -0,02 \end{smallmatrix}$ mm 71,13 mm
	Diamètre alésage du culbuteur	Bohrung des Kipphebels	Bore diameter of rocker	Diámetro alojamiento del balancín	Diametro alesaggio del bilanciere	$14 \begin{smallmatrix} 10,07 \\ 0,03 \end{smallmatrix}$ mm
	Calage de la distribution	Steuerzeiten der Ein- und Auslassventile	Valve opening Angles.	Calado de la distribución	Fasatura della distribuzione	
	R. O. A.	Einlass öffnet	Inlet valve opens	Retraso apertura admisión	R. A. A.	0° 05"
	R. F. A.	Einlass schliesst	Inlet valve closes	Retraso cierre admisión	R. C. A.	49° 15'
	A. O. E.	Auslass öffnet	Exhaust valve opens	Avance apertura escape	A. A. S.	35° 55'
	R. F. E.	Auslass schliesst	Exhaust valve closes	Retraso cierre escape	R. C. S.	3° 30'
			A.T.D.C.	R.A.A.		
			A.B.D.C.	R.C.A.		
			B.B.D.C.	A.A.E.		
			A.T.D.C.	R.C.E.		

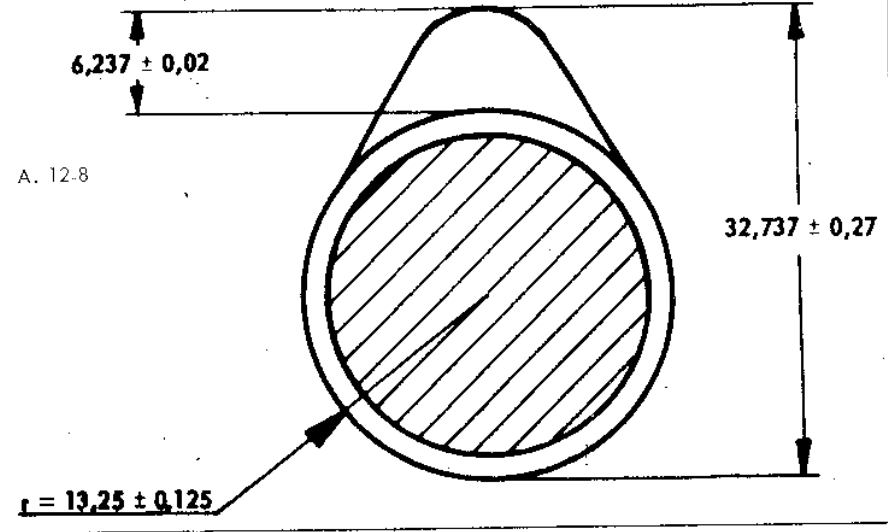
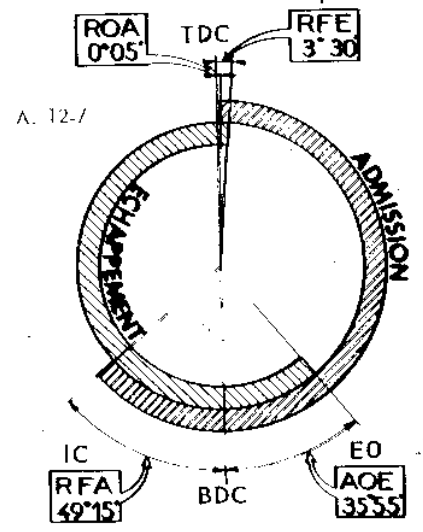
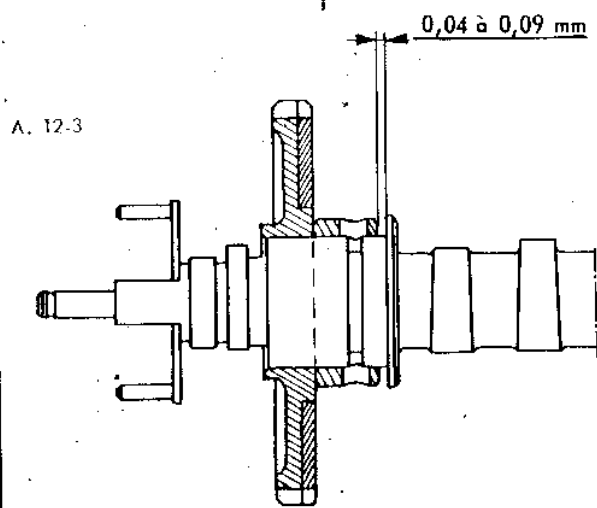

9	MANUAL DE REPARATIONS REPARATURHANBUSCH REPAIR MANUAL MANUAL DE REPARACIONES MANUALE DI RIPARAZIONE	N° 559/1	OPERATIONS ARBEITSVORGÄNGE OPERATIONS OPERACIONES OPERAZIONI	AM3. 100 - 00 AM3. 112 - 3	AMI 8	BERLINE (AM série JA) BREAK (AM série JB) BREAK COMMERCIAL (AM série JB) BREAK SERVICE (AM série JC) 9 - 1969 →
---	---	----------	--	-----------------------------------	-------	--

RESSORTS DE SOUPAPES - VENTILFEDERN - VALVE SPRINGS - MUELLES DE VALVULAS - MOLLE DELLE VALVOLE

Ressort Federn Spring Muelle Molla	Longueur sous charge Länge unter Belastung Length under load Longitud bajo carga Lunghezza sotto carico	Charge Belastung Load Carga Carico	Longueur sous charge Länge unter Belastung Length under load Longitud bajo carga Lunghezza sotto carico	Charge Belastung Load Carga Carico
Exterieur Aussenfeder Outer Exterior Esterna	31,4 mm	28 ± 1,5 kg (58 to 65 lbs)	24,15 mm	42,5 ± 2 kg (89 to 98 lbs)
Intérieur Innenfeder Inner Interior Interna	24,4 mm	12 ± 1 kg (24 1/2 to 26 1/2 lbs)	17,15 mm	25 ± 1,5 kg (52 to 58 lbs)

NOTE

Ressorts de rappel des soupapes

- extérieur: enroulement à droite, longueur maxi à spires jointives,
- intérieur: enroulement à gauche, longueur maxi à spires jointives.

ANM :

Rückholfedern für Ventile

- aussen: Rechtswicklung, Länge bei anliegenden Wicklungen:
- innen: Linkswicklung Länge bei anliegenden Wicklungen:

NOTE :

Valve return spring :

- outer: right hand coil, maximum length compressed
- inner: left hand coil, maximum length compressed

OBSERVACION :

Muelle de retroceso de las válvulas

- exterior: enrollamiento a derechas, longitud máx. con las espiras juntas
- interior: enrollamiento a izquierdas, longitud máx. con las espiras juntas

NOTA :

Molla di richiamo valvola :

- esterna: avvolgimento destro, lunghezza massima con spire adiacenti
- interna: avvolgimento sinistro lunghezza massima con spire adiacenti

22,68 mm

15,39 mm

8 SOUPAPERIE - VENTILE - VALVE GEAR - VALVULAS - VALVOLE

Soupapes à queue conique
 Ventile mit konischem Schaft
 Valves with taper stem
 Válvulas de vástago cónico
 Valvole con gambo conico

Segments d'arrêt à 3 gorges
 3 Nuten für Ventilkleile
 3 groove cutters
 Segmentos de retén de 3 ranuras
 Rosette d'arresto a 3 gole

Jointes d'étanchéité sur guides de soupapes
 Dichtringe auf Ventilführungen
 Seals on valve guides
 Juntas de estanqueidad sobre guías de válvulas
 Guarnizioni di tenuta sulle guidavalvole

SOUPAPES - VENTILE - VALVE - VALVULAS - VALVOLE

Soupapes Ventile Valves Válvulas Valvole	Angle des portées Winkel Face angle Angulo de asientos Angolo delle portate	Ø tête Teller-Ø Dia. (head) Ø Cabeza Ø testa	Ø queue sous tête Schaft - Ø Dia. (Stem) under head Ø vástago bajo cabeza Ø gambo sottotesta	Longueur Länge Length Longitud Lunghezza
Admission Einlass Inlet Admisión Aspirazione	120°	40 mm	8 ^{+0,020} _{-0,035} mm	L ¹ 88,5 ^{+0,45} _{-0,25} mm
Echappement Auslass Exhaust Escape Scarico	90°	34 mm	8,5 ^{+0,035} _{-0,050} mm	L ² 86,95 ^{+0,45} _{-0,25} mm

Soupape admission
 Einlassventil
 Inlet valve
 Válvula admisión
 Valvola d'aspirazione

Soupape échappement
 Auslassventil
 Exhaust valve
 Válvula escape
 Valvola di scarico

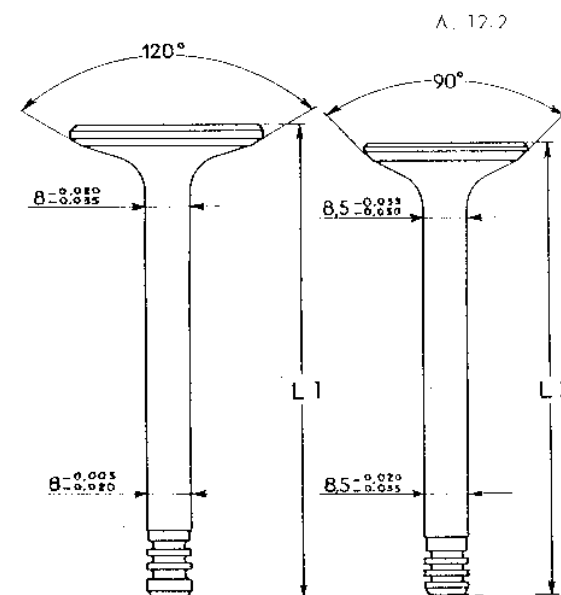

CARBURATEUR - VERGASER - CARBURETTOR - CARBURADOR - CARBUTATORE
 (suite) (Forts.) (continued) (continuación) (seguito)

REGLAGE DU RALENTI :

- Vis de richesse : Amener le régime moteur à 750 T/mn. Visser lentement la vis de richesse jusqu'à ce que le moteur tourne irrégulièrement puis desserrer cette vis de 1/3 de tour.

REGIME : Embrayage classique (26-35 CSIC) : 750 + 50₀ tr/min

Embrayage centrifuge (26-35 SCIC) : à partir du «léchage» du tambour d'embrayage, desserrer la vis de butée de papillons de 1/8 de tour

Frein de ralenti : (embrayage centrifuge) temps de retour : 1 à 2 secondes -

REGLAGE DES COMMANDES

- Accélérateur : Pédale appuyée à fond (avec cale de 4 mm entre pédale et tapis de sol), jeu entre goupille et arrêt de câble 1,5 mm

- Starter : garde à la tirette 3 à 5 mm

EINSTELLUNG D. LEERLAUFS :

- Gemischregulierschraube : Motordrehzahl auf 750 U/min bringen. Die Gemischregulierschraube langsam einschrauben, bis d. Motor unregelmässig läuft, dann diese Schraube wieder um 1/3-Umdrehung lösen.

MOTORDREHZAHN : Normalkupplung (26-35 CSIC) : 750 + 50₀ U/min.

Fliehkraftkupplung (26-35 SCIC) : Wenn die Kupplungstrommel mitgenommen wird, die Drosselklappenanschlagschraube um 1/8 - Umdrehung lösen.

Leerlaufbremse : (Fliehkraft-Kupplung) Rücklaufzeit : 1-2 Sekunden.

EINSTELLUNG DER BETÄTIGUNGEN

Gashebel : bei ganz durchgetretenem Pedal (mit Scheibe von 4 mm zwischen Pedal u. Bodenmatte) beträgt das Spiel zwischen Splint und Zughalterung 1,5 mm.

- Starter : Spiel am Zug 3-5 mm

ADJUST THE IDLING :

- Mixture screw : adjust engine speed to 750 rpm, Screw Mixture screw in slowly until engine begins to hunt, then unscrew Mixture screw 1/3 of a turn.

IDLING SPEED : Conventional clutch : (26-35 CSIC) 750 to 800 rpm

Centrifugal clutch : (26-35 SCIC) : Adjust the idling speed until the clutch drum just begins to drag, then undo the throttle stop screw by 1/8 of a turn

Throttle-closing dashpot (centrifugal clutch) : Closing delay : 1 to 2 secs.

ADJUSTMENT OF CONTROLS :

Accelerator : Pedal fully depressed (4 mm (5/32 IN) spacer between pedal and floor) clearance between pin and cable stop : -1.5 mm (1/16 in).

- Choke : Clearance between knob & guide : 3 to 5 mm $\left(\frac{1 - 3}{8 - 16} \right)$

REGLAJE DEL RALENTI :

- Tornillo de riqueza : Poner el régimen del motor a 750 r.p.m. Apretar lentamente el tornillo de riqueza hasta que el motor gire irregularmente, después aflojar este tornillo 1/3 de vuelta

REGIMEN : Embrague clásico (26-35 SCIC) : 750 + 50₀ rpm

Embrague centrifugo (26-35 SCIC) : a partir del «roce» del tambor de embrague, aflojar, el tornillo del tope de mariposa de 1/8 de vuelta.

Freno de ralenti : (embrague centrifugo) tiempo de retorno 1 a 2 segundos

REGLAJE DE LOS MANDOS

- Acelerador : Pedal pisado a fondo (con delga de 4 mm entre el pedal y el tapiz del suelo), juego entre la grupilla y el freno del cable 1,5 mm

- Starter : distancia al tirador 3 a 5 mm

REGOLAZIONE DEL MINIMO :

- Vite di regolazione miscela : Portare il regime motore a 750 giri/min. Avvitare lentamente la vite di regolazione miscela fino che il motore gira in modo irregolare poi allentare la vite di 1/3 di giro.

REGIME : Frizione classica (26-35 CSIC) : 750 + 50₀ giri/min.

Frizione centrifuga (26-35 SCIC) : a partire dal «pattinamento» del tamburo di frizione, allentare la vite d'arresto farfalla di 1/8 di giro.

Freno del minimo : (frizione centrifuga) tempo di ritorno : 1 a 2 secondi.

REGOLAZIONE DEI COMANDI

- Acceleratore : Pedale premuto a fondo (con spessore da 4 mm tra pedale e tappeto del pianale), gioco tra copiglia ed arresto del cavo 1,5 mm

- Starter : gioco al tirante 3 a 5 mm

I	MANUEL DE REPARATIONS REPARATURHANDBUCH REPAIR MANUAL MANUAL DE REPARACIONES MANUALE DI RIPARAZIONE	N° 559/1	OPERATIONS ARBEITSVORGÄNGE OPERATIONS OPERACIONES OPERAZIONI	AM3. 142 - 3	AMI 8	BERLINE (AM série JA) BREAK (AM série JB) BREAK COMMERCIAL (AM série JB) BREAK SERVICE (AM série JC) 9 - 1969
---	--	----------	---	--------------	-------	---

CARBURATEUR	VERGASER	CARBURETTOR	CARBURADOR	CARBURATORE	SOLEX
-------------	----------	-------------	------------	-------------	-------

TYPE : Embrayage classique 26 - 35 CSIC 1 - 6 - 1970 → 110 ² 1 - 6 - 1970 → 110 ³ Embrayage centrifuge 26 - 35 SCIC 1 - 6 - 1970 → 111 ² 1 - 6 - 1970 → 111 ³	TYP : Normalkupplung 26 - 35 CSIC 1 - 6 - 1970 → 110 ² 1 - 6 - 1970 → 110 ³ Fliehkraftkupplung 26 - 35 SCIC 1 - 6 - 1970 → 111 ² 1 - 6 - 1970 → 111 ³	TYPE : Conventional clutch 26 - 35 CSIC 1 - 6 - 1970 → 110 ² 1 - 6 - 1970 → 110 ³ Centrifugal clutch 26 - 35 SCIC 1 - 6 - 1970 → 111 ² 1 - 6 - 1970 → 111 ³	TIPO : Embrague normal 26 - 35 CSIC 1 - 6 - 1970 → 110 ² 1 - 6 - 1970 → 110 ³ Embrague centrifugo 26 - 35 SCIC 1 - 6 - 1970 → 111 ² 1 - 6 - 1970 → 111 ³	TIPO : Frizione classica 26 - 35 CSIC 1 - 6 - 1970 → 110 ² 1 - 6 - 1970 → 110 ³ Frizione centrifuga 26 - 35 SCIC 1 - 6 - 1970 → 111 ² 1 - 6 - 1970 → 111 ³
---	---	---	--	--

REGLAGES <table style="width: 100%; border-collapse: collapse;"> <tr> <td></td> <td style="text-align: center;">1er corps</td> <td style="text-align: center;">2è corps</td> </tr> <tr> <td>- Buses</td> <td style="text-align: center;">21</td> <td style="text-align: center;">24</td> </tr> <tr> <td>- Gicleurs principaux</td> <td style="text-align: center;">125</td> <td style="text-align: center;">75</td> </tr> <tr> <td>- Porte-tube d'émulsion calibré</td> <td style="text-align: center;">1 FI (145)*</td> <td></td> </tr> <tr> <td>- Gicleur de ralenti</td> <td style="text-align: center;">50</td> <td></td> </tr> <tr> <td>- Injecteur de pompe de reprise</td> <td style="text-align: center;">40</td> <td></td> </tr> <tr> <td>- Ajustage d'automatité</td> <td colspan="2" style="text-align: center;">2AA(120)</td> </tr> <tr> <td>- Pointeau à ressort</td> <td style="text-align: center;">Siège 1,7</td> <td></td> </tr> <tr> <td>- Trous de progression 3 φ</td> <td style="text-align: center;">1 = 80 2 = 90</td> <td></td> </tr> <tr> <td>- Réglage du flotteur (joint monté sur le couvercle)</td> <td style="text-align: center;">35 mm</td> <td></td> </tr> </table>		1er corps	2è corps	- Buses	21	24	- Gicleurs principaux	125	75	- Porte-tube d'émulsion calibré	1 FI (145)*		- Gicleur de ralenti	50		- Injecteur de pompe de reprise	40		- Ajustage d'automatité	2AA(120)		- Pointeau à ressort	Siège 1,7		- Trous de progression 3 φ	1 = 80 2 = 90		- Réglage du flotteur (joint monté sur le couvercle)	35 mm		EINSTELLUNGEN <table style="width: 100%; border-collapse: collapse;"> <tr> <td></td> <td style="text-align: center;">1. Stufe</td> <td style="text-align: center;">2. Stufe</td> </tr> <tr> <td>- Lufttrichter</td> <td style="text-align: center;">21</td> <td style="text-align: center;">24</td> </tr> <tr> <td>- Hauptdüsen</td> <td style="text-align: center;">125</td> <td style="text-align: center;">75</td> </tr> <tr> <td>- Mischrohr</td> <td style="text-align: center;">1 FI (145)*</td> <td></td> </tr> <tr> <td>- Leerlaufdüse</td> <td style="text-align: center;">50</td> <td></td> </tr> <tr> <td>- Pumpendüse</td> <td style="text-align: center;">40</td> <td></td> </tr> <tr> <td>- Luftkorrekturdüse</td> <td colspan="2" style="text-align: center;">2AA(120)</td> </tr> <tr> <td>- Schwimmernadel mit Feder Sitz 1,7</td> <td></td> <td></td> </tr> <tr> <td>- Beschleunigungsbohrungen 3mm φ</td> <td style="text-align: center;">1 = 80 2 = 90</td> <td></td> </tr> <tr> <td>- Einstellung des Schwimmers (Dichtung am Deckel eingebaut)</td> <td style="text-align: center;">35 mm</td> <td></td> </tr> </table>		1. Stufe	2. Stufe	- Lufttrichter	21	24	- Hauptdüsen	125	75	- Mischrohr	1 FI (145)*		- Leerlaufdüse	50		- Pumpendüse	40		- Luftkorrekturdüse	2AA(120)		- Schwimmernadel mit Feder Sitz 1,7			- Beschleunigungsbohrungen 3mm φ	1 = 80 2 = 90		- Einstellung des Schwimmers (Dichtung am Deckel eingebaut)	35 mm		SETTINGS <table style="width: 100%; border-collapse: collapse;"> <tr> <td></td> <td style="text-align: center;">Primary</td> <td style="text-align: center;">secondary</td> </tr> <tr> <td>- Chokes</td> <td style="text-align: center;">21</td> <td style="text-align: center;">24</td> </tr> <tr> <td>- Main jets</td> <td style="text-align: center;">125</td> <td style="text-align: center;">75</td> </tr> <tr> <td>- Emulsion-tube carrier</td> <td style="text-align: center;">1 FI (145)*</td> <td></td> </tr> <tr> <td>- Idling jet</td> <td style="text-align: center;">50</td> <td></td> </tr> <tr> <td>- Accel. pump injector</td> <td style="text-align: center;">40</td> <td></td> </tr> <tr> <td>- Air correction jet</td> <td colspan="2" style="text-align: center;">2AA(120)</td> </tr> <tr> <td>- Needle-valve with spring : 1,7</td> <td></td> <td></td> </tr> <tr> <td>- Progression holes (three)</td> <td style="text-align: center;">1 = 80 dia 2 = 90 dia</td> <td></td> </tr> <tr> <td>- Float position (gasket on cover)</td> <td style="text-align: center;">35 mm</td> <td></td> </tr> </table>		Primary	secondary	- Chokes	21	24	- Main jets	125	75	- Emulsion-tube carrier	1 FI (145)*		- Idling jet	50		- Accel. pump injector	40		- Air correction jet	2AA(120)		- Needle-valve with spring : 1,7			- Progression holes (three)	1 = 80 dia 2 = 90 dia		- Float position (gasket on cover)	35 mm		REGLAJES <table style="width: 100%; border-collapse: collapse;"> <tr> <td></td> <td style="text-align: center;">1er cuerpo</td> <td style="text-align: center;">2º cuerpo</td> </tr> <tr> <td>- Difusores</td> <td style="text-align: center;">21</td> <td style="text-align: center;">24</td> </tr> <tr> <td>- Surtidores principales</td> <td style="text-align: center;">125</td> <td style="text-align: center;">75</td> </tr> <tr> <td>- Porta tubo de de emulsion calibrado</td> <td style="text-align: center;">1 FI (145)*</td> <td></td> </tr> <tr> <td>- Surtidor de ralenti</td> <td style="text-align: center;">50</td> <td></td> </tr> <tr> <td>- Inyector de bomba de repris</td> <td style="text-align: center;">40</td> <td></td> </tr> <tr> <td>- Ajuste de automaticidad</td> <td colspan="2" style="text-align: center;">2AA(120)</td> </tr> <tr> <td>- Aguja de muelle</td> <td style="text-align: center;">Asiento 1,7</td> <td></td> </tr> <tr> <td>- Orificios de progresion 3 φ</td> <td style="text-align: center;">1 = 80 2 = 90</td> <td></td> </tr> <tr> <td>- Reglaje del flotador (junta montada sobre la tapa)</td> <td style="text-align: center;">35 mm</td> <td></td> </tr> </table>		1er cuerpo	2º cuerpo	- Difusores	21	24	- Surtidores principales	125	75	- Porta tubo de de emulsion calibrado	1 FI (145)*		- Surtidor de ralenti	50		- Inyector de bomba de repris	40		- Ajuste de automaticidad	2AA(120)		- Aguja de muelle	Asiento 1,7		- Orificios de progresion 3 φ	1 = 80 2 = 90		- Reglaje del flotador (junta montada sobre la tapa)	35 mm		REGOLAZIONI <table style="width: 100%; border-collapse: collapse;"> <tr> <td></td> <td style="text-align: center;">1º Corpo</td> <td style="text-align: center;">2º Corpo</td> </tr> <tr> <td>- Coni diffusori</td> <td style="text-align: center;">21</td> <td style="text-align: center;">24</td> </tr> <tr> <td>- Getti principali</td> <td style="text-align: center;">125</td> <td style="text-align: center;">75</td> </tr> <tr> <td>- Portatubo d'emulsione calibrato</td> <td style="text-align: center;">1 FI (145)*</td> <td></td> </tr> <tr> <td>- Getto del minimo</td> <td style="text-align: center;">50</td> <td></td> </tr> <tr> <td>- Iniettore della pompa di ripresa</td> <td style="text-align: center;">40</td> <td></td> </tr> <tr> <td>- Calibratore d'automatità</td> <td colspan="2" style="text-align: center;">2AA(120)</td> </tr> <tr> <td>- Valvola a spillo a molla Sede 1,7</td> <td></td> <td></td> </tr> <tr> <td>- Fori di progressione 3 φ</td> <td style="text-align: center;">1 = 80 2 = 90</td> <td></td> </tr> <tr> <td>- Regolazione del galleggiante (guarnizione montata sul coperchio)</td> <td style="text-align: center;">35 mm</td> <td></td> </tr> </table>		1º Corpo	2º Corpo	- Coni diffusori	21	24	- Getti principali	125	75	- Portatubo d'emulsione calibrato	1 FI (145)*		- Getto del minimo	50		- Iniettore della pompa di ripresa	40		- Calibratore d'automatità	2AA(120)		- Valvola a spillo a molla Sede 1,7			- Fori di progressione 3 φ	1 = 80 2 = 90		- Regolazione del galleggiante (guarnizione montata sul coperchio)	35 mm	
	1er corps	2è corps																																																																																																																																																								
- Buses	21	24																																																																																																																																																								
- Gicleurs principaux	125	75																																																																																																																																																								
- Porte-tube d'émulsion calibré	1 FI (145)*																																																																																																																																																									
- Gicleur de ralenti	50																																																																																																																																																									
- Injecteur de pompe de reprise	40																																																																																																																																																									
- Ajustage d'automatité	2AA(120)																																																																																																																																																									
- Pointeau à ressort	Siège 1,7																																																																																																																																																									
- Trous de progression 3 φ	1 = 80 2 = 90																																																																																																																																																									
- Réglage du flotteur (joint monté sur le couvercle)	35 mm																																																																																																																																																									
	1. Stufe	2. Stufe																																																																																																																																																								
- Lufttrichter	21	24																																																																																																																																																								
- Hauptdüsen	125	75																																																																																																																																																								
- Mischrohr	1 FI (145)*																																																																																																																																																									
- Leerlaufdüse	50																																																																																																																																																									
- Pumpendüse	40																																																																																																																																																									
- Luftkorrekturdüse	2AA(120)																																																																																																																																																									
- Schwimmernadel mit Feder Sitz 1,7																																																																																																																																																										
- Beschleunigungsbohrungen 3mm φ	1 = 80 2 = 90																																																																																																																																																									
- Einstellung des Schwimmers (Dichtung am Deckel eingebaut)	35 mm																																																																																																																																																									
	Primary	secondary																																																																																																																																																								
- Chokes	21	24																																																																																																																																																								
- Main jets	125	75																																																																																																																																																								
- Emulsion-tube carrier	1 FI (145)*																																																																																																																																																									
- Idling jet	50																																																																																																																																																									
- Accel. pump injector	40																																																																																																																																																									
- Air correction jet	2AA(120)																																																																																																																																																									
- Needle-valve with spring : 1,7																																																																																																																																																										
- Progression holes (three)	1 = 80 dia 2 = 90 dia																																																																																																																																																									
- Float position (gasket on cover)	35 mm																																																																																																																																																									
	1er cuerpo	2º cuerpo																																																																																																																																																								
- Difusores	21	24																																																																																																																																																								
- Surtidores principales	125	75																																																																																																																																																								
- Porta tubo de de emulsion calibrado	1 FI (145)*																																																																																																																																																									
- Surtidor de ralenti	50																																																																																																																																																									
- Inyector de bomba de repris	40																																																																																																																																																									
- Ajuste de automaticidad	2AA(120)																																																																																																																																																									
- Aguja de muelle	Asiento 1,7																																																																																																																																																									
- Orificios de progresion 3 φ	1 = 80 2 = 90																																																																																																																																																									
- Reglaje del flotador (junta montada sobre la tapa)	35 mm																																																																																																																																																									
	1º Corpo	2º Corpo																																																																																																																																																								
- Coni diffusori	21	24																																																																																																																																																								
- Getti principali	125	75																																																																																																																																																								
- Portatubo d'emulsione calibrato	1 FI (145)*																																																																																																																																																									
- Getto del minimo	50																																																																																																																																																									
- Iniettore della pompa di ripresa	40																																																																																																																																																									
- Calibratore d'automatità	2AA(120)																																																																																																																																																									
- Valvola a spillo a molla Sede 1,7																																																																																																																																																										
- Fori di progressione 3 φ	1 = 80 2 = 90																																																																																																																																																									
- Regolazione del galleggiante (guarnizione montata sul coperchio)	35 mm																																																																																																																																																									

* Valeurs moyennes	* Durchschnittswerte	* Average sizes.	* Valores medios	* Valori medi
--------------------	----------------------	------------------	------------------	---------------

CARBURATEUR

VERGASER

CARBURETTOR

CARBURADOR

CARBURATORE

TYPE
TYP
TYPE
TIPO
TIPO

26-35 CSIC 110²26-35 SCIC - 111²

TYPE
TYP
TYPE
TIPO
TIPO

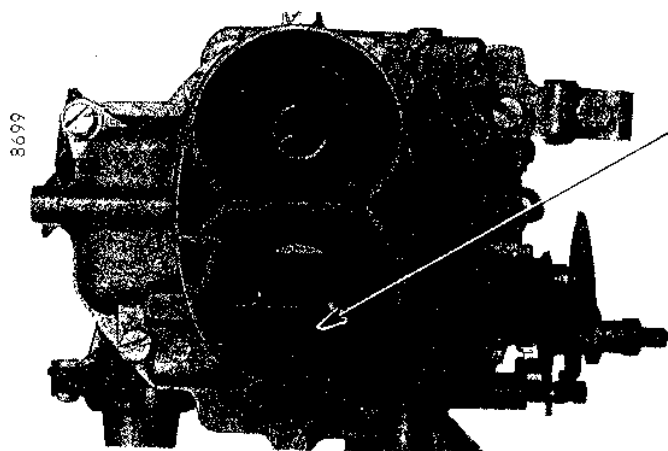
26-35 CSIC 110³26-35 SCIC - 111³

Ancien volet de départ
à froid

Frühere Klappe für
Kaltstart

Previous strangler flap

Antigua mariposa de
arranque en frío

Parzializzatore d'avvia-
mento a freddo precedente

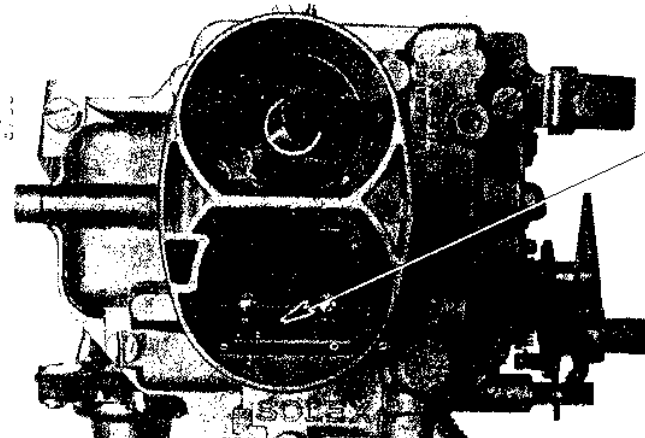

Nouveau volet de départ
à froid

Neue Klappe für
Kaltstart

New Strangler flap

Mariposa moderna de
arranque en frío

Parzializzatore d'avvia-
mento a freddo attuale.

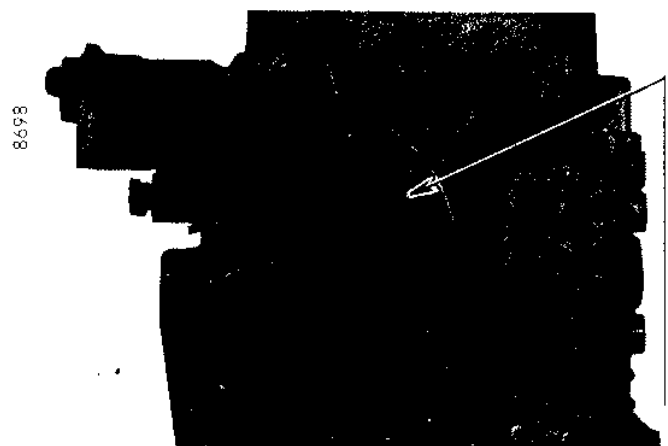

Ancienne came
de commande

Früherer
Betätigungsnocken

Previous control cam

Antigur leva de mando

Eccentrico di comando
precedente

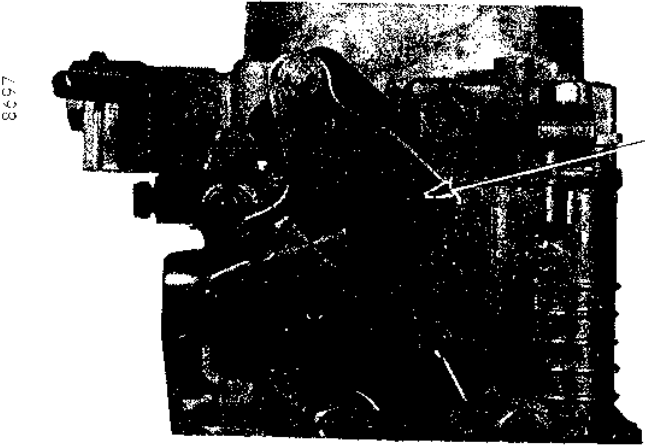

Nouvelle came de
commande

Neuer
Betätigungsnocken

New control cam

Leva moderna de mando

Eccentrico di comando
attuale

CARBURATEUR - VERGASER - CARBURETTOR - CARBURADOR - CARBURATORE

(suite)

(Forts)

(continued)

(continuación)

(seguito)

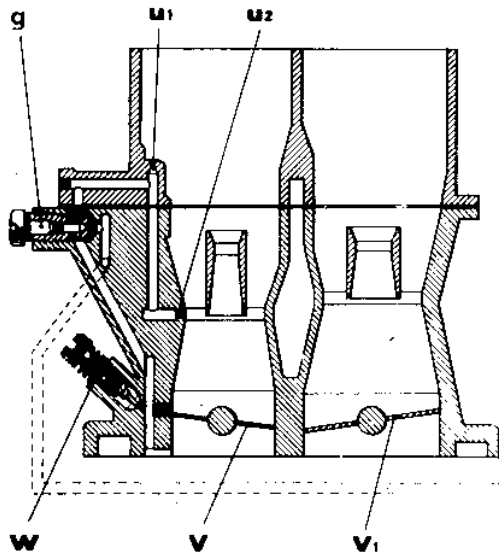

A. 14-3

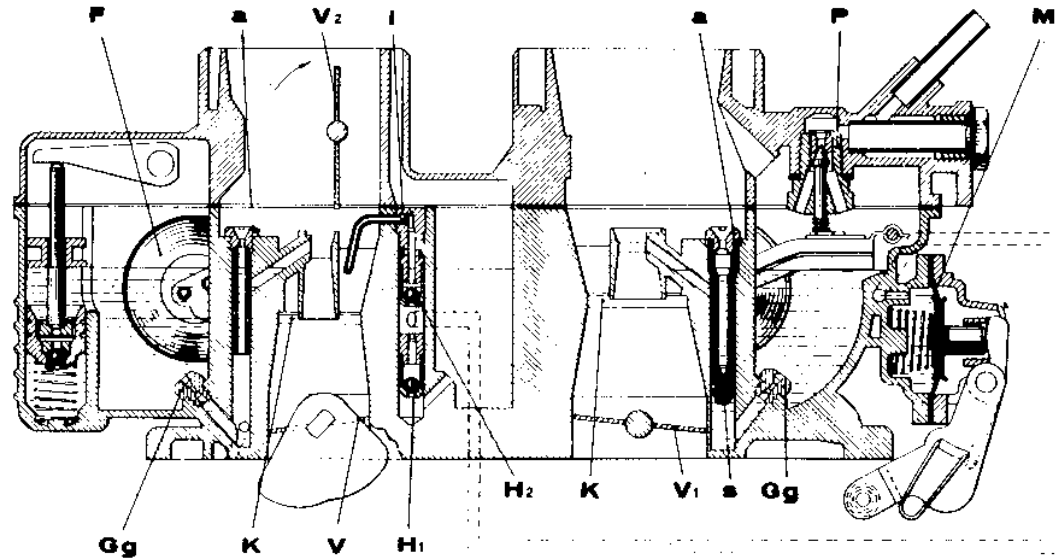

a	Ajoutages d'automatité	a	Luftkorrekturdüse	a	Correction jets	a	Ajuste de automaticidad	a	Calibratore aria di automaticità
F	Flotteur	F	Schwimmer	F	Float	F	Flotador	F	Galleggiante
Gg	Gicleurs d'alimentation	Gg	Hauptdüse	Gg	Main jets	Gg	Surtidor de alimentación	Gg	Getto d'alimentazione
g	Gicleur de ralenti	g	Beschleunigerdüse	g	Pilot jet	g	Surtidor de ralenti	g	Getto del minimo
H ¹ H ²	Sièges de bille	H ¹ H ²	Rückschlagventil	H ¹ H ²	Pump inlet valve	H ¹ H ²	Asientos de bola	H ¹ H ²	Sede della sfera
i	Injecteur de pompe	i	Einspritzdüse	i	Pump injector	i	inyector de bomba	i	Iniettore della pompa
K	Buses d'air	K	Lufttrichter	K	Choke tubes	K	Boquilla de aire	K	Diffusore aria
M	Membrane de pompe	M	Membrane der Pumpe	M	Pump membrane	M	Membrana de la bomba	M	Membrana della pompa
P	Pointeau à ressort	P	Schwimmernadelventil	P	Needle valve with spring	P	Aguja con muelle	P	Valvola a spillo a molla
s	Tube d'emulsion	s	Mischrohr	s	Emulsion tube	s	Tubo de emulsión	s	Tubo di emulsione
u ¹ u ²	Orifices calibrés	u ¹ u ²	Ausgleichsbohrung	u ¹ u ²	Calibrated orifices	u ¹ u ²	Orificios calibrados	u ¹ u ²	Fori calibrati
V V ¹	Papillons des gaz	V V ¹	Drosselklappe	V V ¹	Throttles	V V ¹	Mariposas de gases	V V ¹	Farfalle dei gas
V ²	Volet de depart	V ²	Starterklappe	V ²	Strangler	V ²	Mariposa de arranque	V ²	Parzializzatore d'avviamento
W	Vis de richesse de ralenti	W	Leerlaufgemischregulier-Schraube	W	Idling Mixture Screw	W	Tornillo de riqueza del ralenti	W	Vite di regolazione miscela del minimo

2	MANUEL DE REPARATIONS REPARATURHANDBUCH REPAIR MANUAL MANUAL DE REPARACIONES MANUALE DI RIPARAZIONE	N 559/1	OPERATIONS ARBEITSVORGÄNGE OPERATIONS OPERACIONES OPERAZIONI	AM3. 141 - 1 AM3. 175 - 1	AMI 8	BERLINE (AM série JA) BREAK (AM série JB) BREAK COMMERCIAL (AM série JB) BREAK SERVICE (AM série JC) 9 - 1969 
RESERVOIR A ESSENCE	KRAFTSTOFFTANK	PETROL TANK	DEPOSITO DE GASOLINA	SERBATOIO CARBURANTE	31 l Relumix	
<ul style="list-style-type: none"> - Capacité (litres) - Element filtrant 	<ul style="list-style-type: none"> - Inhalt (Liter) - Kraftstofffilter 	<ul style="list-style-type: none"> - Capacity (litres) - Filter element 	<ul style="list-style-type: none"> - Capacidad (litros) - Elemento filtrante 	<ul style="list-style-type: none"> - Capacità (litri) - Elemento filtrante 		
JAUGE A ESSENCE	KRAFTSTOFFANZEIGE	PETROL GAUGE	INDICADOR DE GASOLINA	INDICATORE LIVELLO	12 Volts ED. - Jaeger	
Rhéostat de jauge	Rheostat	Gauge rheostat	Reóstato de indicador	Reostato dell'indicatore		
<p>NOTE : Par la trappe du réservoir, vérifier que le tube d'alimentation se trouve en ligne avec l'extrémité du tube plongeur. Si le raccord caoutchouc est monté en contrainte il se rompra très rapidement.</p>	<p>ANM. : Durch die Zugangs- klappe zum Tank hindurch kontrollieren, ob sich das Zufuhrrohr mit dem Ende des Tauchrohres in einer Linie befindet. Wenn die Gummiverbindung so eingebaut ist, dass sie verkantet ist, wird sie sehr schnell brechen.</p>	<p>NOTE : Remove the access panel and ensure that the rubber pipe is in line with the metal outlet pipe. If the rubber pipe is twisted or bent, it will break rapidly.</p>	<p>NOTA : Por el registro del depósito, verificar que el tubo de alimentación se encuentra en línea con la extremidad del tubo sumer- gido. Si el racor de goma se monta en contracción, se rompera muy rápidamente.</p>	<p>NOTA : Dal coperchio del serbatoio, verificare che il tubo d'alimentazione si trovi allineato con l'e- sternità del tubo pescante. Se il manicotto di gomma è montato di sbieco, esso si romperà molto rapidamente.</p>		
TUBULURE ADMISSION ET ECHAPPEMENT	EIN- UND AUSLASS- KRUMMER	INLET AND EXHAUST MANIFOLD	COLECTOR ADMISION Y ESCAPE	COLLETTORE DI ASPIRAZIONE - SCARICO	0,1 mm 1,5 mkg (10,8 ft lbs) 1 à 2 mkg (7,2 TO 8,7 ft lbs)	
<ul style="list-style-type: none"> - Défaut de planéité de la face d'appui des brides de fixation - Serrage des écrous des brides de fixation - Serrage des demi-colliers sur tubes d'échappement 	<ul style="list-style-type: none"> - Planheitstoleranz der Auflageflächen der Befestigungsflansche - Anzugsmoment der Muttern der Befestigungsflansche - Anzugsmoment der Schellenhälften an den Auslassröhren 	<ul style="list-style-type: none"> - Flange faces to be flat to within - Tightening of flange nuts - Tightening of manifold half collars 	<ul style="list-style-type: none"> - Defecto de planicidad de la cara de apoyo de las bridas de fijación - Apriete de las tuercas de las bridas de fijación - Apriete de los medio-collarines sobre los tubos de escape 	<ul style="list-style-type: none"> - Falsa planarità delle facce d'appoggio delle flange di fissaggio - Serraggio dadi delle flange di fissaggio - Serraggio mezzi collari sui tubi di scarico 		

1	MANUEL DE REPARATIONS REPARATURHANDBUCH REPAIR MANUAL MANUAL DE REPARACIONES MANUALE DI RIPARAZIONE	N° 559/1	OPERATIONS ARBEITSVORGÄNGE OPERATIONS OPERACIONES OPERAZIONI	AM3. 173 - 1 AM3. 173 - 3	AMI 8	BERLINE (AM série JA) BREAK (AM série JB) BREAK COMMERCIAL (AM série JB) BREAK SERVICE (AM série JC) 9 - 1969 →
---	---	----------	--	----------------------------------	-------	--

ACCESSOIRES D'ALIMENTATION	KRAFTSTOFFZUFUHR	FUEL SUPPLY	ACCESORIOS DE ALIMENTACION	ACCESSORI DELL'ALIMENTAZIONE	
FILTRE A AIR Filtre à air «Miofiltre» élément filtrant imprégné d'huile NOTE : Résonateur d'admission et filtre à air incorporés dans le même boîtier	LUFTFILTER Luftfilter «Miofiltre» Filterelement mit Öl imprägniert ANM : Ansaugeräuschkämpfer im gleichen Gehäuse	AIR FILTER Air filter «Miofiltre» filter element impregnated with oil NOTE : Resonance chamber and filter are in the same casing	FILTRO DE AIRE Filtro de aire «Miofiltre» elemento filtrante impregnado de aceite OBSERVACION : Resonador de admisión y filtro de aire incorporado en la misma caja	FILTRO DELL'ARIA Filtro dell'aria «Miofiltre» elemento filtrante imbevuto d'olio NOTA : Silenziatore di aspirazione e filtro aria incorporati nella stessa scatola	
POMPE A ESSENCE - Contrôle d'étanchéité (air comprimé) - Pression de refoulement (à débit nul) - Dépassement de la tige de commande de la pompe (came en position mini) - Longueur de la tige de commande - Course de la tige de commande	BENZINPUMPE Dichtigkeitskontrolle (Pressluft) Benzinpumpendruck (im Leerlauf) Überstand des Betätigungsstössels der Pumpe (Nocke auf niedrigster Position) Länge des Pumpenstössels Hub des Pumpenstössels	PETROL PUMP Checking for leaks (compressed air) Output pressure (zero delivery) Pump operating rod stands proud by (cam in min. position) Length of control rod Control rod travel	BOMBA DE GASOLINA Control de estanqueidad (aire comprimido) Presión de impulsión (con caudal nulo) Sobresaliente de la varilla de mando de la bomba (leva en posición mini) Longitud de la varilla de mando Carrera de la varilla de mando	POMPA BENZINA - Controllo della tenuta (aria compressa) - Pressione di mandata (erogazione nulla) - Sporgenza dell'asta di comando pompa (camma in posizione minima) - Lunghezza asta di comando - Corsa asta di comando	GUIOT S.E.V. Marchal 800 gr/cm ² (12 p.s.i.) 200 gr/cm ² (3 p.s.i.) 1,2 mm mini 110,7 ⁰ _{-0,1} mm 2,6 ⁰ _{-0,16} mm

1 MANUEL DE REPARATIONS REPARATURMANDBUCH REPAIR MANUAL MANUAL DE REPARACIONES MANUALE DI RIPARAZIONE		N° 559/1		OPERATION ARBEITSVORGÄNGE OPERATIONS OPERACIONES OPERAZIONI		AM3. 000 AM3. 211 - 0		AMI 8 BERLINE (AM serie JA) BREAK (AM serie JB) BREAK COMMERCIAL (AM serie JB) BREAK SERVICE (AM serie JC) 9 - 1969 	
ALLUMAGE BOBINE Référence ALLUMEUR Référence : POINT D'ALLUMAGE : 8° avant PMH - Ecartement des vis platinées - Angle de fermeture des vis platinées - Pression de tarage du ressort (linguet mobile) - Débattement des masses d'avance centrifuge BOUGIES Ecartement des électrodes CONDENSATEUR Capacité	ZÜNDUNG ZÜNDSPULE Bezeichnung ZÜNDVERTEILER Bezeichnung : ZÜNDZEITPUNKT : 8° vor O.T. Unterbrecherkontaktabstand Schliesswinkel Tariendruck der Feder Blattfeder Zündverstellung durch Fliehgewichte ZÜNDKERZEN Elektrodenabstand KONDENSATOR Kapazität	IGNITION COIL Reference CONTACT BREAKER Référence : STATIC SETTING : 8° B.T.D.C. Breaker point gap Dwell angle Contact pressure of spring (moving contact) Centrifugal advance SPARKING PLUGS Sparking plug gap CONDENSER Capacity	ENCENDIDO BOBINA Referencia DISTRIBUIDOR DE ENCENDIDO Referencia : PUNTO DE ENCENDIDO : 8° antes P.M.S. Separación entre los platinos Angulo de cierre de los platinos Presión de tarado del muelle (lengueta móvil) Desplazamiento de las masas de avance centrifugo BUJIAS Separación de electrodos CONDENSADOR Capacidad	ACCENSIONE BOBINA Riferimento SPINTEROGENO Riferimento : PUNTO D'ACCENSIONE : 8° dopo il P.M.S. Apertura dei contatti Angolo di chiusura dei contatti Pressione di taratura della molla (martelletto mobile) Escursione delle masse d'anticipo centrifugo CANDELE Distanza degli elettrodi CONDENSATORE Capacità	DUCELLIER 4009 DUCELLIER 605774 0,40 ± 0,05 mm (0,016" ± 0,002") 144 ± 2° 450 à 550 g (16 to 19 oz) 10 à 15° S.E.V. Marchal 34S - AC42 FF 0,6 à 0,7 mm (0,024" to 0,028") 0,18 à 0,22 µ F				

RHEOSTAT DE JAUGE - RHEOSTAT - GAUGE RHEOSTAT
 REOSTATO DE INDICADOR - REOSTATO DELL'INDICATORE

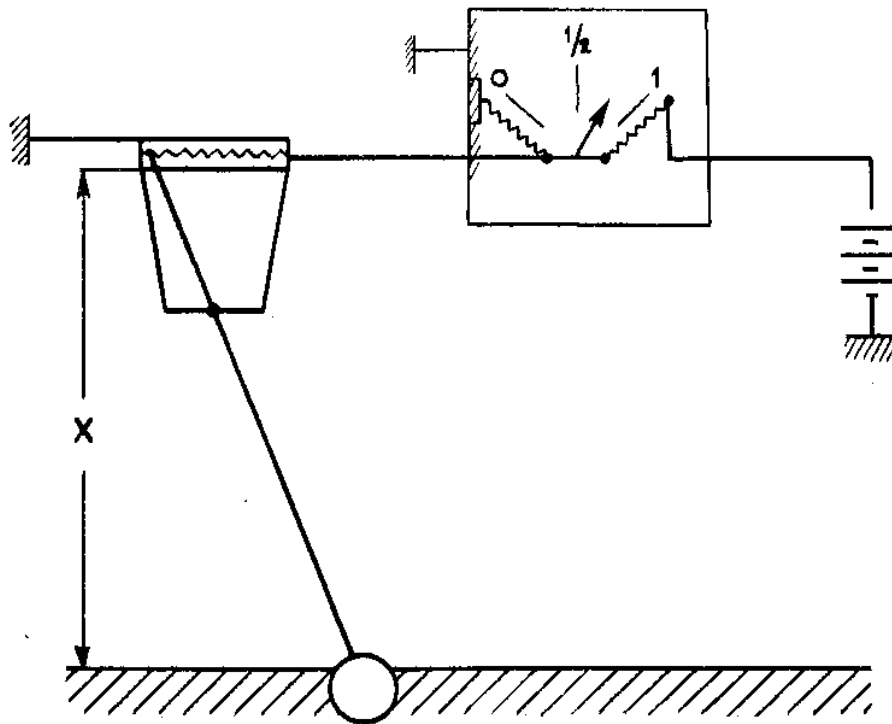

NIVEAU DU LIQUIDE
 FLÜSSIGKEITSSTAND
 LIQUID LEVEL
 NIVEL DEL LIQUIDO
 LIVELLO DEL LIQUIDO

- Lorsque l'axe de l'aiguille sera confondu avec l'axe du repère, les valeurs de X seront comprises entre les valeurs du tableau ci-dessous :
- Wenn die Nadelachse mit der Achse der Markierung genau übereinstimmt, so liegen die Werte von X zwischen den Werten der untenstehenden Tabelle.
- When the centre-line of the needle coincides with the centre-line of the mark, the values of X will lie between the values given in table below.
- Cuando el eje de la aguja coincide con el eje del punto de referencia, los valores de X estarán comprendidos entre los valores del cuadro abajo señalado.
- Quando l'asse della lancetta coincide con l'asse del riferimento, i valori di X saranno compresi tra quelli della tabella qui di seguito.

REPERES MARKIERUNGEN MARKS PUNTO DE REFERENCIA RIFERIMENTI	0	1/2	1
X MAXI	162 mm	108,5 mm	55 mm
X MINI	153 mm	97 mm	0

1	MANUEL DE REPARATIONS REPARATURHANDBUCH REPAIR MANUAL MANUAL DE REPARACIONES MANUALE DI RIPARAZIONE	OPERATIONS ARBEITSVORGÄNGE OPERATIONS OPERACIONES OPERAZIONI	AM3. 100 - 00 AM3. 100 - 3 AM3. 220 - 0	AMI 8 BERLINE (AM serie JA) BREAK (AM serie JB) BREAK COMMERCIAL (AM serie JB) BREAK SERVICE (AM serie JC) 9 - 1969 	
GRAISSAGE Huile moteur CONTENANCE DU CARTER - après vidange - après démontage des couvre-culasses - entre mini et maxi POMPE A HUILE - Epaisseur des pignons - Jeu latéral des pignons dans le corps - Serrage des vis de fixation du couvercle (avec joint papier entre carter et corps de pompe à huile) - Pression d'huile à 6000 tr/min (huile à 80°C) (manomètre branché à la sortie du $\frac{1}{2}$ carter gauche).	SCHMIERUNG Motoröl FASSUNGSVERMÖGEN DES MOTORGEHÄUSES - Nach Ölwechsel - Nach Abbau der Zylinderkopfdeckel - Zwischen Mini u. Maxi ÖLPUMPE - Stärke der Pumpenräder - Seitenspiel der Pumpenräder im Gehäuse - Anzugsmoment der Befestigungsschrauben des Pumpendeckels (mit Papierdichtung zwischen Gehäuse und Ölpumpenkörper) - Öldruck bei 6000 U/min (Öl auf 80°C) (Manometer angeschlossen am Ausgang der linken Gehäuseshälfte).	LUBRICATION Engine oil CAPACITY OF SUMP - after draining - after removing cylinder head cover - between min and max. marks OIL PUMP - Thickness of pinions - End float of pinions in pump body - Tightening the screws securing the cover (paper gasket between crankcase and oil-pump body) - Oil pressure at 6000 RPM (oil at 80°C) (gauge connected to outlet on left hand half crankcase).	ENGRASE Aceite motor CAPACIDAD DEL CARTER - después vaciado - después desmontaje tapa culatas - entre mini y máxi. BOMBA DE ACEITE - Espesor de los piñones - Juego lateral de los piñones en el cuerpo - Apriete de los tornillos de fijación de la tapa (con junta de papel entre el cárter y cuerpo de la bomba de aceite) - Presión de aceite a 6000 RPM (aceite a 80°C) (manómetro conectado a la salida del $\frac{1}{2}$ cárter izquierdo).	LUBRIFICAZIONE Olio motore CAPACITÀ DEL CARTER - per sostituzione - dopo smontaggio dei coperchi testata - fra minimo e massimo POMPA DELL'OLIO - Spessore degli ingranaggi - Gioco assiale degli ingranaggi nel corpo - Serraggio viti di fissaggio coperchio (con guarnizione di carta tra carter e corpo pompa dell'olio) - Pressione olio a 6000 giri/min (olio a 80°C) (manometro collegato all'uscita del $\frac{1}{2}$ carter sinistro).	TOTAL Altigrade GT spéciale autoroute 20 W 40 2,2 L (3,9 pts. imp) 2,5 L (4,4 pts. imp) 0,5 L ($\frac{7}{8}$ pt. imp) 10,5 - 0,02 - 0,05 mm 0,02 à 0,10 mm 1,3 mkg (9 $\frac{1}{2}$ ft lbs) 4 à 5 kg/cm ² (58 TO 72 PSI)

- AVANCE, ALLUMEUR
- FRÜHZÜNDUNG VERTEILER-GRADE
- ADVANCE, CONTACT BREAKER
- CURVA DE AVANCE DEL DISTRIBUIDOR
- ANTICIPO SPINTEROGENO

A. 21-53

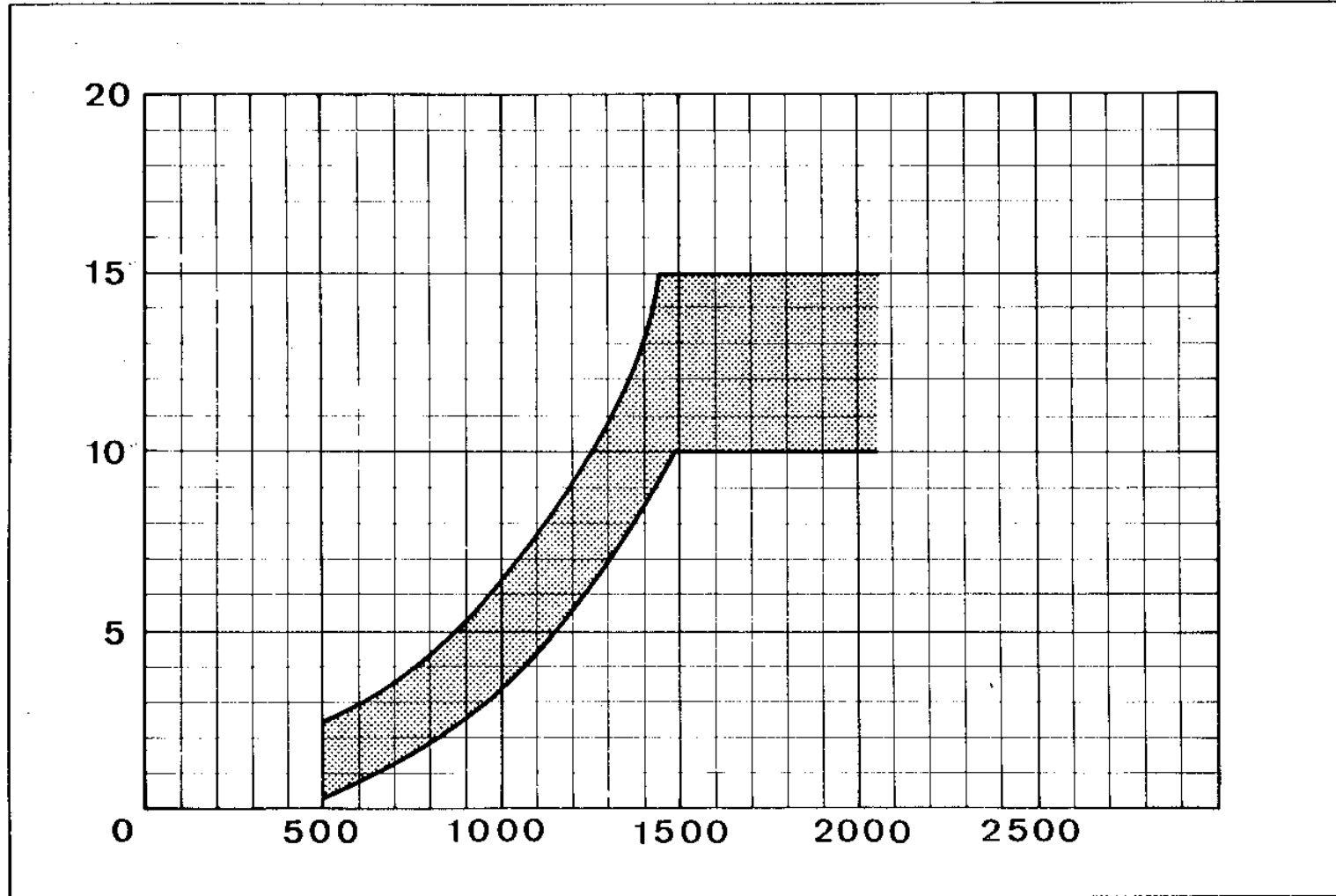

- Tr mm ALLUMEUR
U/min. VERTEILER

- R.P.M. CONTACT BREAKER
- R.P.M. DEL DISTRIBUIDOR
- GIRI/min. SPINTEROGENO

MANUEL DE REPARATIONS
REPARATURHANDBUCH
REPAIR MANUAL
MANUAL DE REPARACIONES
MANUALE DI RIPARAZIONE

N° 559/1

OPERATIONS
ARBEITSVORGÄNGE
OPERATIONS
OPERACIONES
OPERAZIONI

AM3-220-2

AMI 8

BERLINE (AM Série JA)
BREAK (AM Série JB)
BREAK COMMERCIAL (AM Série JB)
BREAK SERVICE (AM Série JC)
17-11-1969

GRAISSAGE
(suite)

SCHMIERUNG
(Forts.)

LUBRICATION
(continued)

ENGRASE
(continuación)

LUBRIFICAZIONE
(seguito)

FILTRE A HUILE

Note : Depuis le 17-11-1969 le tamis d'huile est modifié. Le tamis d'huile AM222-6A est remplacé par un tamis avec cartouche filtrante incorporée AM 222-128 A.

Serrage du nouveau tamis avec une vis (1) ZC9621359U et une rondelle contact.

- Couple de serrage :

Avec ce tamis, vidange obligatoire tous les 2500 kms.

ÖLFILTER

ANM.: Ab 17.11.1969 ist das Ölfiltersieb geändert. Das Ölfiltersieb AM 222-6A wird durch das Ölfiltersieb AM 222-128 A mit eingebauter Filterpatrone ersetzt.

Anzug des neuen Siebes mit einer Schraube (1) ZC9621359U und einer Kontaktscheibe.

- Anzugsmoment :

Mit diesem Filtersieb ausgerüstete Wagen müssen alle 2500 km einem Ölwechsel vornehmen.

OILFILTER

Note : Since 17-11-1969 the oil filter has been modified. The strainer AM 222-6A is replaced by a strainer with filter cartridge incorporated, AM 222-128 A.

The new filter is fitted with a screw (1) ZC9621359U and a «Contact» washer.

- Tighten to :

With this filter it is essential to change the engine oil every 1500 miles.

FILTRO DE ACEITE

Observación : A partir del 17-11-1969 el tamiz de aceite AM 222-6A ha sido reemplazado por un tamiz con cartucho filtrante incorporado AM 222-128 A.

Apriete del nuevo tamiz con un tornillo (1) ZC9621359U y una arandela de contacto.

- Par de apriete :

Con este tamiz el cambio de aceite es obligatorio todos los 2500 km.

FILTRO DELL'OLIO

Nota : Dal 17-11-1969 la reticella filtrante è modificata. La reticella AM222-6A è sostituita da un filtro con cartuccia filtrante incorporata AM 222-128 A.

Serraggio del nuovo filtro con una vite (1) ZC9621359U e una rondella di contatto.

- Coppia di serraggio :

Con questo filtro sostituzione obbligatoria dell'olio ogni 2500 km.

± 0,1
1 0' m.kg
(7 to 8 ft. lbs)



7477

CIRCULATION D'HUILE MOTEUR

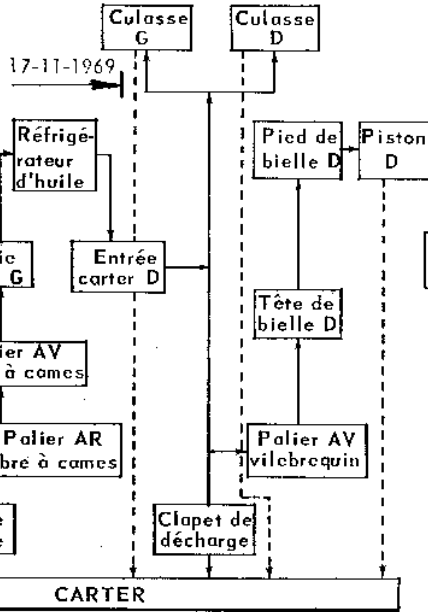

SCHMIERKREISLAUF MOTOR

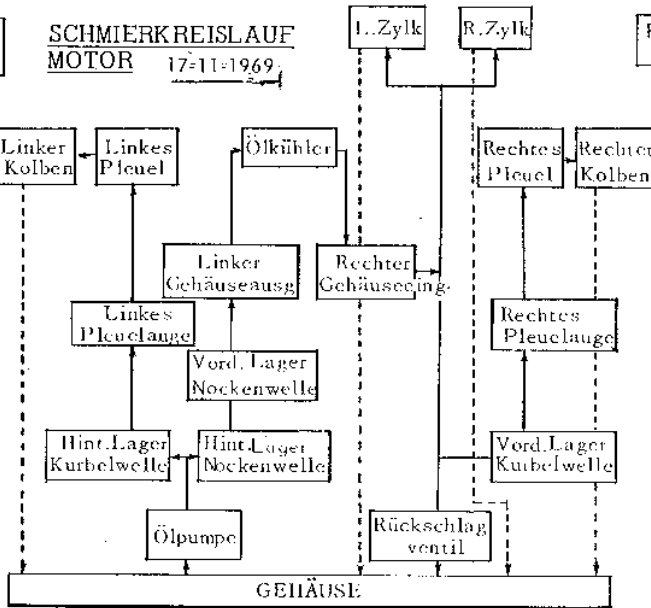

ENGINE OIL CIRCULATION

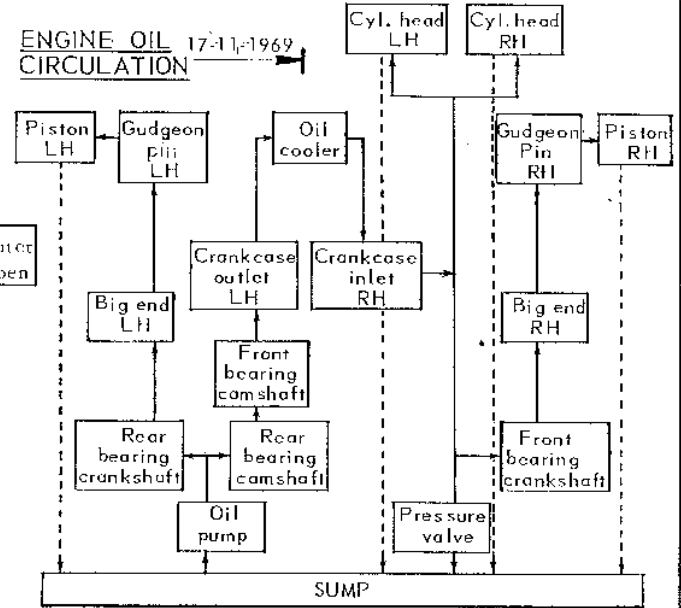

CIRCULACION DE ACEITE MOTOR

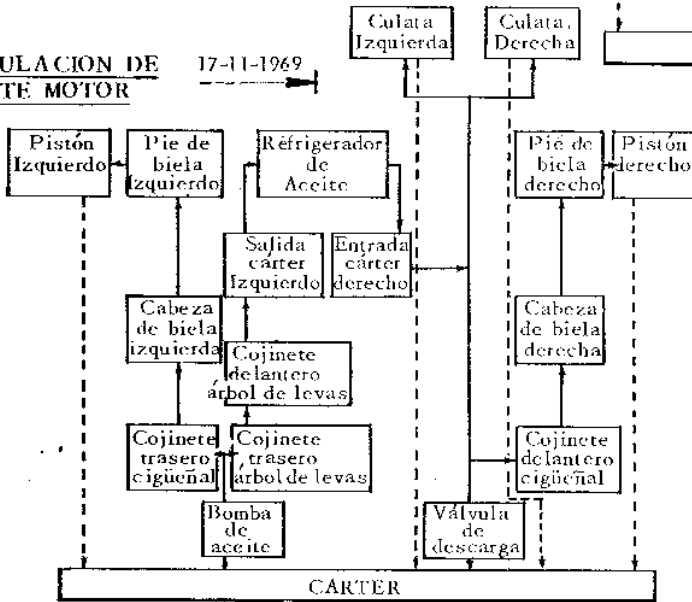

CIRCOLAZIONE OLIO MOTORE

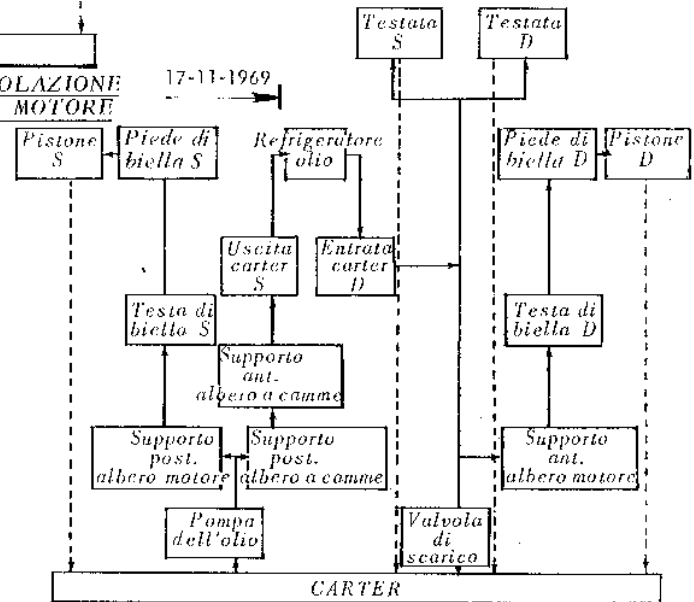

5	MANUEL DE REPARATIONS REPARATURHANDBUCH REPAIR MANUAL MANUAL DE REPARACIONES MANUALE DI RIPARAZIONE	OPERATIONS ARBEITSVORGÄNGE OPERATIONS OPERACIONES OPERAZIONI	AMI 8	BERLINE (AM série JA) BREAK (AM série JB) BREAK COMMERCIAL (AM série JB) BREAK SERVICE (AM série JC) 6-10-1969 	
GRAISSAGE (suite) Depuis le 6-10-1969, un mano-contact de pression d'huile est monté sur les moteurs qui équipent ces véhicules. Le mano-contact AYB 614-112A est fixé sur le demi-carter moteur gauche à la place du bouchon obturateur AZ 114-91. L'étanchéité est réalisée par un joint 2458-S. Couple de serrage du mano-contact: Le voyant de pression d'huile DX 521-233 A est fixé sur la partie centrale de la planche de bord AM 856-286 A. Le mano-contact est relié par un fil au faisceau avant.	SCHMIERUNG (Forts.) Ab. 6-10-1969 wird ein Warnlichtschalter für Öldruck bei den Motoren dieser Fahrzeuge eingebaut. Der Warnlichtschalter AYB 614-112A wird an der linken Motorgehäusehälfte anstelle des Verschlussstopfens AZ 114-91 befestigt. Die Dichtigkeit wird gewährleistet durch eine Dichtung 2458-S. Anzugsmoment des Warnlichtschalters: Die Kontrolleuchte für Öldruck DX 521-233 A wird am Mittelteil des Armaturenbrettes AM 856-286 A befestigt. Der Warnlichtschalter ist mit einem Kabel mit den vorderen Kabelbündel verbunden.	LUBRICATION (continued) Since 6-10-1969, an oil pressure switch is fitted on the engines on these vehicles. The pressure-switch, AYB 614-112A is fixed on the left hard half-crankcase in place of the closing plug AZ 114-91. Oil-tightness is ensured by a joint 2458-S. Tighten pressure switch to: The oil pressure warning lamp DX 521-233 A is fixed on the central portion of the fascia board AM 856-286 A. The pressure switch is connected by a lead to the front harness.	ENGRASE (continuación) A partir del 6-10-1969 se monta un manocontacto de presión de aceite sobre los motores que equipan estos vehículos. El manocontacto AYB 614-112A está fijado sobre el semi cárter de motor lado izquierdo en lugar del tapón obturador AZ 114-91. La estanqueidad se obtiene por una junta 2458-S. Par de apriete del manocontacto: La luz de control de la presión de aceite DX 521-233 A está fijada sobre la parte central del tablero de abordó AM 856-286 A. El manocontacto está conectado por un cable al haz delantero.	LUBRIFICAZIONE (seguito) Dal 6-10-1969 un manocontacto della pressione olio è montato sui motori di questi veicoli. Il manocontacto AYB 614-112A è fissato sul semicarter motore sinistro al posto del tappo AZ 114-91. La tenuta è assicurata da una guarnizione 2458-S. Coppia di serraggio del manocontacto: La spia della pressione olio DX 521-233 A è fissata sulla parte centrale del cruscotto AM 856-286 A. Il manocontacto è collegato con un filo al fascio anteriore.	$2 \begin{matrix} +0,2 \\ 0 \end{matrix} \text{ m.kg}$ (14 to 16 ft lbs)

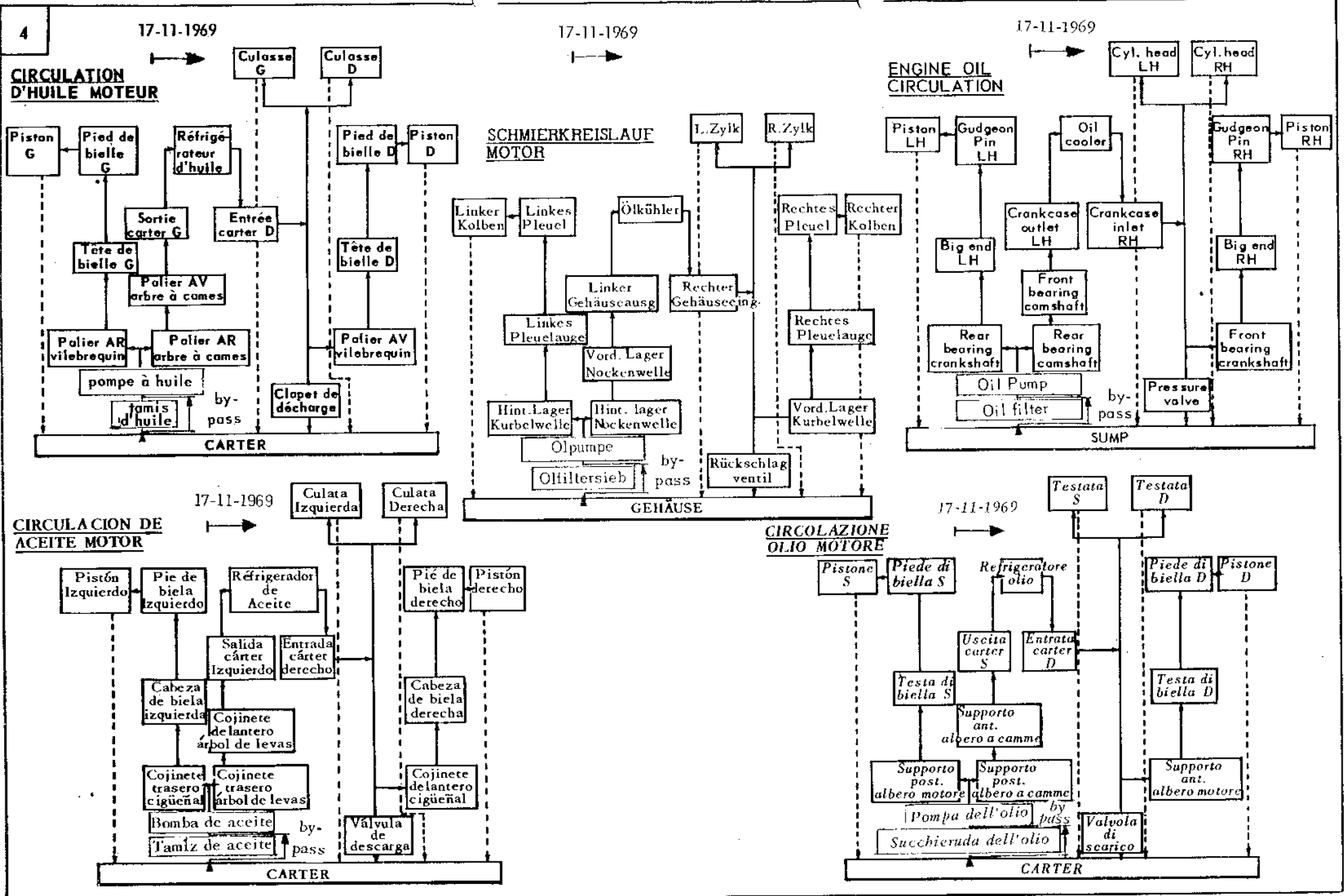

1	MANUEL DE REPARATIONS REPARATURHANDBUCH REPAIR MANUAL MANUAL DE REPARACIONES MANUALE DI RIPARAZIONE	N° 559/1	OPERATIONS ARBEITSVORGÄNGE OPERATIONS OPERACIONES OPERAZIONI	AM3. 220 - 0	AM3. 220 - 1	AMI 8	BERLINE (AM serie JA) BREAK (AM serie JB) BREAK COMMERCIAL (AM serie JB) BREAK SERVICE (AM serie JC)	9-1969
REFRIGERATEUR D'HUILE	ÖLKÜHLER	OIL COOLER	REFRIGERADOR DE ACEITE	REFRIGERATORE DELL'OLIO	<p>9 105 cm³ 1,75 cm² (9 lames) (9 tubes) 1 à 1,2 mka (7.2 to 8.7 Ft lbs)</p>			
<ul style="list-style-type: none"> - Nombre d'éléments - Capacité - Section de passage d'huile - Serrage des écrous raccord sur carter 	<ul style="list-style-type: none"> - Anzahl der Teile - Inhalt - Querschnitt des Öldurchganges - Anzugsmoment der Verbindungsmuttern am Gehäuse. 	<ul style="list-style-type: none"> - Number of tubes - Capacity - Area of oil flow 	<ul style="list-style-type: none"> - Número de elementos - Capacidad - Sección de paso de aceite - Apriete de los tornillos racores sobre cárter 	<ul style="list-style-type: none"> - Numero di elementi - Capacità - Sezione di passaggio dell'olio - Serraggio viti raccordo sul carter 				
<p>NOTE : La garniture-joint est à remplacer à chaque démontage. Elle doit être en retrait de 2 mm de l'extrémité du tube.</p>	<p>ANM : Gummitüllen nach jedem Ausbau auswechseln. Sie müssen 2 mm vom Rohrende zurückstehen.</p>	<p>NOTE : The sleeve seal must be renewed each time the pipe is disconnected. It must be fitted so that the tube protrudes by 2 mm-</p>	<p>NOTA : La junta casquillo se reemplaza en cada desmontaje. Debe tener un retraso de 2 mm desde la extremidad del tubo</p>	<p>NOTA : La guarnizione va sostituita dopo ogni smontaggio. Essa dev'essere rientrante di 2 mm dalla estremità del tubo</p>				
RENIFLARD	ENTLÜFTUNGSVENTIL	BREATHER	RESPIRADERO Ó RENIFLARD	SFIATATOIO	<p>6 cm mini (2 3/8 in w.g.min)</p>			
<ul style="list-style-type: none"> - Dépression dans le carter (manomètre à eau) : - au ralenti 	<ul style="list-style-type: none"> - Unterdruck im Gehäuse (Wassermanometer) : - Motor im Leerlauf 	<ul style="list-style-type: none"> - Vacuum in crankcase (water gauge) : - idling 	<ul style="list-style-type: none"> - Depresión en el cárter (manómetro de agua) : - en ralentí 	<ul style="list-style-type: none"> - Depressione nel carter (manometro ad acqua) : - al minimo 				
COUPLES DE SERRAGE	ANZUGSMOMENTE	TIGHTENING TORQUES	PARES DE APRIETE	COPPIE DI SERRAGGIO	<p>1,3 mkg (9 1/2 Ft.lbs) 4 à 4,5 mka (29 to 33 Ft lbs) 3 mkg (22 Ft lbs)</p>			
<ul style="list-style-type: none"> - Vis raccord des tubes de graissage de culasse - Bouchon de clapet de décharge - Bouchon d'obturation de circuit d'huile 	<ul style="list-style-type: none"> - Verbindungsschrauben an den Schmierrohren der Zylinderköpfe - Ölablassschraube - Ölkreislaufverschluss-schraube 	<ul style="list-style-type: none"> - Screwed unions on lubrication pipes to cyl head - Plug on pressure valve - Closing plug on oil circuit 	<ul style="list-style-type: none"> - Tornillo racor de los tubos de engrase de culata - Tapón válvula de descarga - Tapón de cierre circuito de aceite. 	<ul style="list-style-type: none"> - Viti raccordo dei tubi di lubrificazione testate - Tappo della valvola di scarico - Tappo di otturazione circuito dell'olio 				

MANUEL DE REPARATIONS
REPARATURHANDBUCH
REPAIR MANUAL
MANUAL DE REPARACIONES
MANUALE DI RIPARAZIONE

N° 538/1

OPERATIONS
ARBEITSVORGÄNGE
OPERATIONS
OPERACIONES
OPERAZIONI

NT - 120A

AMI 8

BERLINE (AM Série JA)
BREAK (AM Série JB)
BREAK COMMERCIAL (AM Série JB)
BREAK SERVICE (AM Série JC)

8-12-69
→

GRAISSAGE
(suite)

Note : Depuis le 8-12-1969 le piston de clapet de décharge est modifié. Le piston de clapet de décharge AM 222-13 A (1) monté depuis le 9-6-1969 est remplacé par le piston de clapet de décharge AM 222-115 A (2).

- Pression obtenue avec le piston (2) :
- Température de l'huile

SCHMIERUNG
(Forts.)

ANM : Ab 8-12-1969 ist der Kolben für das Überdruckventil geändert. Der Kolben für das Überdruckventil AM 222-13 A (1), der ab 9-6-1969 eingebaut wurde, ist durch den Kolben für das Überdruckventil AM 222-115 A (2) ersetzt worden.

- Mit Kolben (2) erreichter Druck :
- Öltemperatur :

LUBRICATION
(continued)

Note : Since 8-12-1969 the pressure-relief valve piston has been modified. Piston AM 222-13 A (1) fitted since 9-6-1969 is replaced by piston AM 222-115 A (2).

- Pressure obtained with piston (2) :
- Oil temperature :

ENGRASE
(continuación)

Observación : A partir del 8-12-1969 el pistón de la válvula de descarga ha sido modificado. El pistón de válvula de descarga AM 222-13 A (1) que se montaba desde el 9-6-1969 ha sido remplazado por el pistón de válvula de descarga AM 222-115 A (2).

- Presión obtenida con el pistón (2) :
- Temperatura del aceite :

LUBRIFICAZIONE
(seguito)

Nota : Dall' 8-12-1969 il pistone della valvola di scarico è modificato. Il pistone della valvola di scarico AM 222-13 A (1) montato dal 9-6-1969 è sostituito dal pistone della valvola di scarico AM 222-115 A (2).

- Pressione ottenuta con il pistone (2) :
- Temperatura dell'olio :

$6 \begin{matrix} 1 \\ 0 \end{matrix} \begin{matrix} 0,5 \\ 0 \end{matrix} \text{ kg/cm}^2$ à 6000 tr/mn
(85 to 92 psi)
80° C (176° F)

7622

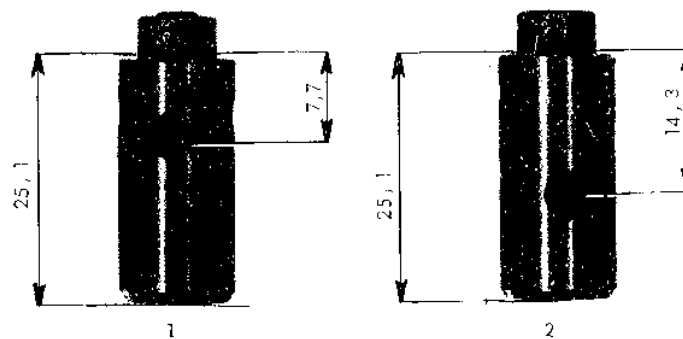

2	REFROIDISSEMENT	KÜHLSYSTEM	COOLING	REFRIGERACIÓN	RAFFREDDAMENTO	
	<p>Refroidissement par air pulsé</p>	<p>Luftkühlung</p>	<p>Cooling by fan (air cooling)</p>	<p>Refrigerado por aire pulsado</p>	<p>Raffreddamento ad aria forzata</p>	
	<p>Montage du ventilateur Pistons au P.M.H., orienter le ventilateur de telle façon qu'à la mise en place de la manivelle, celle-ci soit horizontale.</p>	<p>Einbau des Ventilators : Kolben in O.T. bringen Ventilator so ausrichten, dass beim Einbringen der Andrehkurbel diese horizontal steht.</p>	<p>Fitting fan : Pistons at T.D.C. fit fan so that when inserting the starting-handle it is horizontal.</p>	<p>Montaje del ventilador : Pistones en P.M.S., orientar el ventilador de tal manera que poniendo la manivela, esta quede horizontal.</p>	<p>Montaggio del ventilatore : Pistoni al P.M.S., orientare il ventilatore in modo che la manovella risulti orizzontale.</p>	
	<p>Serrage de la vis de fixation du moyeu support (ou poulie) de ventilateur.</p>	<p>Anzugsmoment der Schraube der Ventilator-nabe (Keilriemenscheibe).</p>	<p>Tightening of securing screw of the fan hub (or pulley).</p>	<p>Apriete, del tornillo de fijación del buje soporte (o polea) del ventilador.</p>	<p>Serraggio vite di fissaggio del mozzo supporto (o puleggia) del ventilatore.</p>	<p>5 mkg (36 ft lbs)</p>
	<p>Serrage des vis de fixation de ventilateur sur moyeu-support ou poulie.</p>	<p>Befestigungsschrauben des Ventilators auf der Nabe bzw. der Keilriemenscheibe.</p>	<p>Tightening the screws securing the fan to the hub (or pulley).</p>	<p>Apriete de los tornillos de fijación del ventilador sobre buje soporte ó polea.</p>	<p>Serraggio viti di fissaggio ventilatore sul mozzo-supporto o puleggia.</p>	<p>1 mkg MAXI. (7 ft lbs)</p>
	<p>Jeu entre boîtier de ventilation et alternateur.</p>	<p>Spiel zwischen Gehäuse und Lichtmaschinenbelüftung.</p>	<p>Clearance between engine cowl and alternator.</p>	<p>Distancia entre carcasa de ventilación y alternador</p>	<p>Gioco tra scatola di ventilazione ed alternatore.</p>	<p>2 mm</p>
	<p>NOTE : Au démontage : ne pas donner de choc sur la dent de loup, ce qui risquerait de fausser le vilebrequin.</p>	<p>ANM. : Beim Ausbau keinen Schlag auf die Anwerfklaue geben, da sonst die Kurbelwelle verbogen werden könnte</p>	<p>NOTE : When removing, do not strike the starting dog, as the crankshaft could be damaged.</p>	<p>OBSERVACIÓN : En el desmontaje : no golpear en la parte dentada ya que habria riesgo de falsear el cigueñal.</p>	<p>NOTA : Allo smontaggio : non dare colpi sull'innesto a griffe per non rischiare di falsare l'albero motore.</p>	

7	MANUEL DE REPARATIONS REPARATURHANDBUCH REPAIR MANUAL MANUAL DE REPARACIONES MANUALE DI RIPARAZIONE	N° 559/2	OPERATIONS ARBEITSVORGÄNGE OPERATIONS OPERACIONES OPERAZIONI	AM3 312-00 AM3 312-0 a AM3 312-3 AM3 314-0	AMI 8	BERLINE (AM série JA) BREAK (AM série JB) BREAK COMMERCIAL (AM série JB) BREAK SERVICE (AM série JC) 9 - 1969 
EMBRAYAGE	KUPPLUNG	CLUTCH	EMBRAGUE	FRIZIONE	FERODO PKHB 4,8	
- Embrayage avec butée à billes	- Kupplung mit Anschlag für Ausrücklager	- Clutch with ball thrust	- Embrague con cojinete de bolas	Frizione con reggispinta a sfere	6 RUBIS (RED) 17,75 mm	
MECANISME Type	MECHANISMUS Typ	MECHANISM Type	MECANISMO Tipo	MECCANISMO Tipo	FERODO A 3 S	
RESSORTS Nombre Couleur φ Extérieur = Longueur sous charge de 37 ± 3 Kg	FEDERN Stückzahl Farbe Aussen-φ = Länge unter Belastung 37 ± 3 Kg	SPRINGS Number Colour External φ = Length under a load of 37 ± 3 kg (81.6 lbs ± 6.6 lbs)	MUELLES Número de muelles Color φ Extérieur = Longitud bajo carga de 37 ± 3 kg	MOLLE Numero Colore φ Esterno = Lunghezza sotto carico 37 ± 3 kg	25 mm	
DISQUE Marque Garnitures Voile maxi sur φ = 150 (à l'état libre)	MITNEHMERSCHEIBE Hersteller Beläge Max. Schlag bei 150 mm φ (entspannt)	DISC Make Linings Maximum runout on a 150 mm φ (free state)	DISCO Marca Guarniciones Alaveo máxi. sobre φ 150 (en estado libre)	DISCO Marca Guarniture Falsa perpendicolarità massima sul φ = 150 (allo stato libero) Spessore originale	FERODO A 3 S 0,4 mm (0,016 in)	
Epaisseur d'origine	Stärke, original	Original thickness	Espesor de origen	Spessore originale	7,4 + 0,05 - 0,25 mm	
CABLE DE DEBRAYAGE Longueur	KUPPLUNGSSEIL Länge	CLUTCH CABLE Length	CABLE DE DESEMBRAGUE Longitud	CAVO FRIZIONE Lunghezza	634 mm	
REGLAGES Mecanisme (voir figure) Position du tambour d'embrayage (emb.cent) Distance entre face d'assemblage du carter d'embrayage et bossage recevant le roulement du tambour (plus bague 3101 T)	EINSTELLUNGEN Mechanismus (s Abb.) Stellung der Kupplungstrommel (Fiehkraftkupplung) Abstand zwischen Auflager Kupplungsgeläuse u. Wulst, welcher das Kugellager in der Trommel aufnimmt (Plus Buchse 3101 T)	ADJUSTMENTS Mecanisme (see Illustration) Position of clutch drum (centrif.clutch) Distance between assembly face on clutch casing and boss holding drum bearing (plus bush 3101 T)	REGLAJES Mecanismo (ver figura) Posición del tambor de embrague (emb.centrif.) Distancia entre cara de acoplamiento del cárter de embrague y el abultamiento que aloja el rodamiento del tambor (1 anillo 3101 T)	REGOLAZIONI Mecanismo (ved. figura) Posizione del tamboro frizione (friz.centrif.) Distanza tra faccia di assemblaggio della campana frizione e rilievo ricevente il cuscinetto del tamboro (piu boccola 3101 T)	5,12 à 5,42 mm	

2	HAUTEUR DE PEDALE	PEDALHÖHE	HEIGHT OF PEDAL	ALTURA DEL PEDAL	ALTEZZA PEDALE	m - 117 à 120 mm
	GARANTIE D'EMBRAYAGE: - à la butée - à la pédale NOTE : Le réglage s'effectue côté pédalier COUPLES DE SERRAGE : - vis de fixation du volant (à remplacer à chaque intervention) - écrou de fixation du tambour (embr. centr.) - vis de fixation de la couronne porte maselettes (embr.cent.)	Kupplungsspiel am : - Anschlag - Pedal Anm: die Einstellung erfolgt von der Pedalseite ANZUGSMOMENTE : Schraube zur Befestigung der Schwungscheibe (nach Eingriff erneuern) Mutter zur Befestigung der Trommel (Flkft.Kuppl.) Schraube zur Befestigung des Fliehkraftkranzes (Flkft-Kuppl.)	CLUTCH CLEARANCE : - at the stop - at the pedal NOTE : The adjustment is made from the pedal-gear end. TIGHTENING TORQUES : - screws securing flywheel (to be renewed after each dismantling) - nut securing drum (centrifugal clutch) - screws securing weight carrying ring (centrifugal clutch)	GARANTIA DE EMBRAGUE: - al cojinete - al pedal OBSERVACION : El reglaje se efectua lado soporte pedal PARES DE APRIETE : - tornillos de fijación del volante (a cambiar en cada intervención) - tuerca de fijación del tambor (Embr.cent.) - tornillos de fijación de la corona porta mazarotas (embr. centr.)	GIOCO FRIZIONE : - al reggispinta - al pedale NOTA : La regolazione si effettua lato pedaliera COPPIE DI SERRAGGIO - viti di fissaggio volante (da sostituire ad ogni intervento) - dado di fissaggio tamburo (frizione centr.) - viti di fissaggio corona portamasse centrifughe (frizione cent.)	1 à 1,5 mm (3/64 to 1/16 in) 20 à 25 mm (0.8 to 1 in) 3,8 mkg (27,5 FT lbs) 3 1 0,10 mkg 0 (21,7 to 29 FT lbs) 0,9 à 1,4 mkg (6,5 to 10 FT lbs)

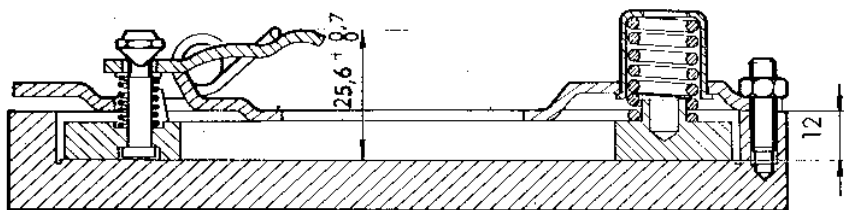

A. 31-3

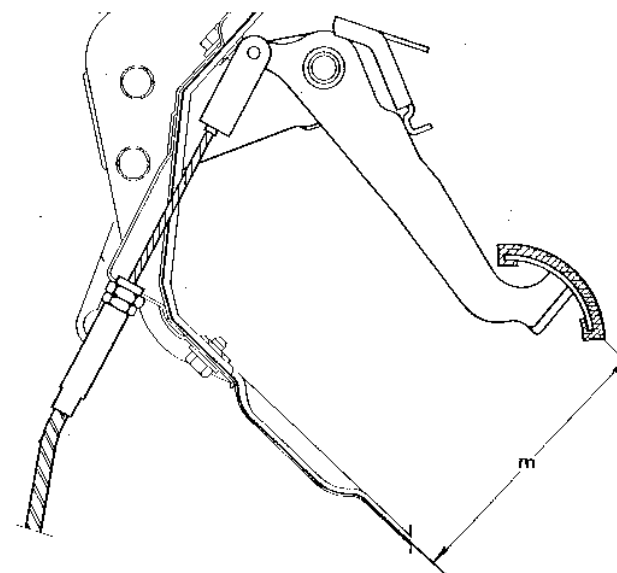

A. 31-1

1	MANUEL DE REPARATIONS REPARATURHANDBUCH REPAIR MANUAL MANUAL DE REPARACIONES MANUALE DI RIPARAZIONE	N° 559/2	OPERATIONS ARBEITSVORGÄNGE OPERATIONS OPERACIONES OPERAZIONI	AM3 330-00	AMI 8	BERLINE (AM serie JA) BREAK (AM serie JB) BREAK COMMERCIAL (AM serie JB) BREAK SERVICE (AM serie JC) 9-1969 →
---	---	----------	--	------------	-------	--

BOITE DE VITESSES - GETRIEBE - GEARBOX - CAJA DE VELOCIDADES - SCATOLA CAMBIO

VITESSES GÄNGE GEARS VELOCIDADES VELOCITÀ	DEMULTIPLICATION ÜBERSETZUNG TOOTH RATIOS DEMOLTIPLICACION DEMOLTIPLICAZIONE	RAPPORT B.V GETRIEBE- GEARBOX RATIOS RELACION C.V RAPPORTO S.C.	COUPLE CONIQUE TELLER-KEGEL- RAD CROWN WHEEL & PINION GRUPO CÓNICO COPPIA CONICA	DEMULTIPLICATION TOTALE GESAMT-ÜBERSETZUNG OVERALL RATIOS DESMOLTIPLICACION TOTAL DEMOLTIPLICAZIONE TOTALE	Vitesse à 1000 tr/mn en km/h GESCHWINDIGKEIT IN KM/h bei 1000 U/min Speed at 1000 R.P.M. Velocidad a 1000 R.P.M. en km/h Velocità a 1000 GIRI/MIN. in km/h	
					125 - 380 X	135 - 380 X
1ère	$\frac{20}{27} \times \frac{14}{31} \times \frac{13}{25} =$	0,1739 (5.75 : 1)		0,0448 (22.32 : 1)	4,953 (3.08 mph)	5,00 (3.11 mph)
2ème	$\frac{20}{27} \times \frac{23}{26} \times \frac{13}{25}$	0,3407 (2.93/1)	$\frac{8}{31}$	0,0879 (11.38 : 1)	9,719 (6.03 mph)	9,82 (6.09 mph)
3ème	$\frac{13}{25} =$	0,5200 (1.923 : 1)	(3.875 : 1)	0,1341 (7.457 : 1)	14,828 (9.22 mph)	14,981 (9.31 mph)
4ème	$\frac{20}{27}$	0,7407 (1.38/1)		0,1911 (5.23 : 1)	21,131 (13.15 mph)	21,35 (13.28 mph)
M.A.R.	$\frac{20}{27} \times \frac{14}{31} \times \frac{13}{25} =$	0,1739 (5.75/1)		0,0448 (22.32 : 1)	4,953 (3.08 mph)	5,00 (3.11 mph)

Note : Développement sous charge des pneus :- 125-380X = 1,843 m - 135-380X = 1,862 m	ANM: Abrollumfang der Reifen 125-380X = 1,843 m 135-380X = 1,862 m	Note: Rolling circumference of tyres -125-380X 1,843m(72.54 in) -135-380X 1,862 m(73.3 in)	Observación: Desarrollo en carga de los neumáticos :-125-380X 1,843m -135-380X 1,862m	Nota: Sviluppo, sotto carico, dei pneumatici:- 125-380 X 1,843 m -135-380 X 1,862 m
---	---	--	---	---

MANUEL DE REPARATIONS
REPARATURHANDBUCH
REPAIR MANUAL
MANUAL DE REPARACIONES
MANUALE DI RIPARAZIONE

N° 559/2

OPERATIONS
ARBEITSVORGÄNGE
OPERATIONS
OPERACIONES
OPERAZIONI

AM3. 330 - 00
AM3. 330 - 3
AM3. 330 - 6

AMI 8

BERLINE (AM série JA)
BREAK (AM série JB)
BREAK COMMERCIAL (AM série JB)
BREAK SERVICE (AM série JC)
9 - 1965

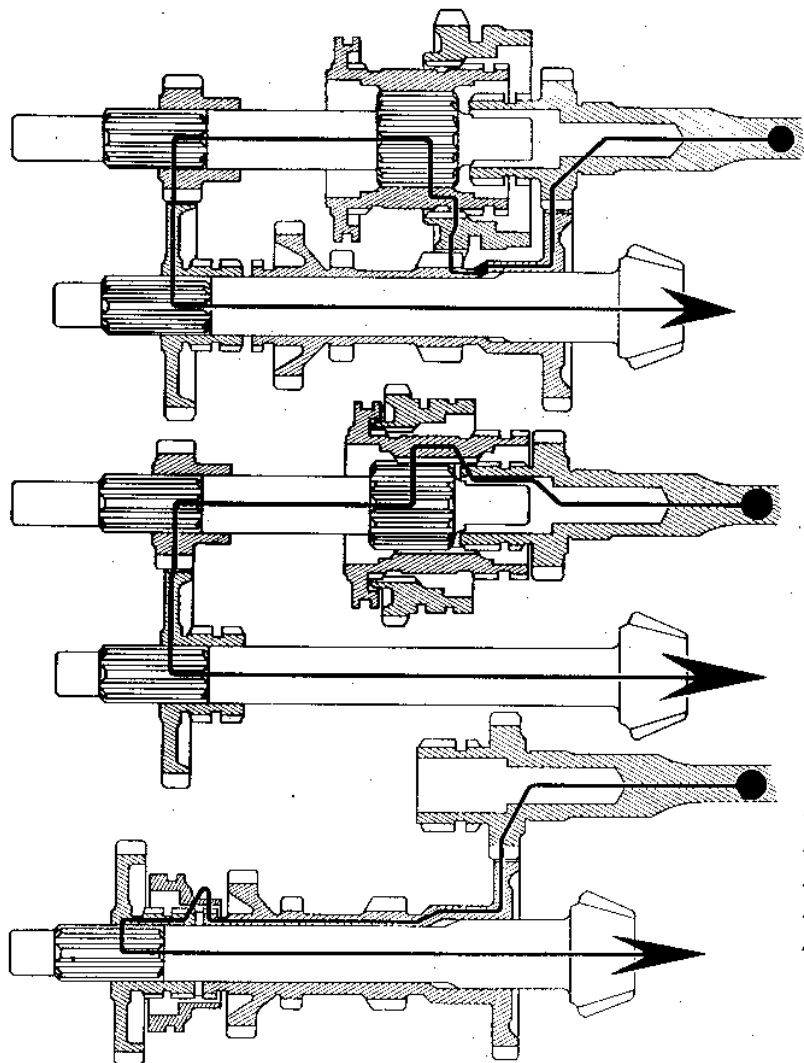

1^{ère} vitesse
1. Gang
1st gear
1^{era} velocidad
1^a velocità

3^e vitesse
3. Gang
3rd gear
3^a velocidad
3^a velocità

4^e vitesse
4. Gang
4th gear
4^a velocidad
4^a velocità

2^e vitesse
2. Gang
2nd gear
2^a velocidad
2^a velocità

- M.A.R
- Rückwärtsgang
- reverse
- marcha atrás
- retromarcia

ces 2 pignons
sont en prise

ces 2 pignons
sont en prise

A. 33-5

Diese beid. Ritzel. s. im Eingriff - Estos 2 piñones están conectados
These 2 pinions are engaged - Questi 2 ingranaggi sono in presa

BOITE DE VITESSES GETRIEBE - GEARBOX - CAJA DE VELOCIDADES - SCATOLA CAMBIO
 (suite) (Forts) (continued) (continuación) (seguito)

RAPPORT DE COMPTEUR	TACHOMETER	SPEEDOMETER DRIVE	RELACIÓN C ^{TA} Km	RAPPORTO DEL CONTA- CHILOMETRI	
Vis de compteur	Schnecke	Speedo drive worm	Tornillo sinfín de cuenta - Kms	Vite senza fine del contachilometri	4 } Filets Gänge Start Filets Filetti
Pignon de compteur	Ritzel	Speedo drive pinion	Pinón del C ^{TA} Kms	Pignoncino del conta- chilometri	16 } Dents Zähne Teeth Dientes Denti
JEUX	SPIEL	CLEARANCE	JUEGOS	GIOCHI	
Pignon fou de 2 ^{ème} Jeu latéral :	Nebenritzel d.2. Ganges Seitenspiel :	End float, 2 nd Gear loose pinion :	Pinón loco de 2 ^a Juego lateral :	Ingranaggio folle della 2 ^a Gioco assiale :	0,05 à 0,35 mm
Train intermédiaire Jeu latéral :	Vorgelegewelle Seitenspiel :	End float, intermediate gear :	Tren intermedio Juego latéral :	Treno intermedio Gioco assiale :	0,10 à 0,20 mm
Alésage de la bague du pignon de M.AR. :	Bohrung d.Buchse des R.W.Gang-Ritzels	Bore of rev. pinion bush :	Diámetro del casquillo del piñón de M. atrás :	Alesaggio della boccola dell'ingranaggio della R.M.	12 ± 0,027 mm
COUPLES DE SERRAGE	ANZUGSMOMENTE	TIGHTENING TORQUES	PARES DE APRIETE	COPPIE DI SERRAGGIO	
Ecrou du pignon d'attaque	Mutter des Anttriebs- ritzels	Bevel pinion shaft nut	Tuerca del piñón de ataque	Dado del pignone cónico	7 à 8,5 mkg (51 to 62 FT lbs)
Ecrou de l'arbre primaire	Mutter der Primärwelle	Main shaft nut	Tuerca del eje primario	Dado dell'albero primario	7 à 9 mkg (51 to 65 FT lbs)
GRAISSAGE	SCHMIERUNG	LUBRICATION	ENGRASE	LUBRIFICAZIONE	
Huile Contenance.L.	Öl Inhalt. in L.	Oil Capacity. L.	Accite Capacidad. L.	Olio Capacità L.	TOTAL EP 80 0,9 (1,6 PT. imp)

4

MANUEL DE REPARATIONS
 REPARATURHANDBUCH
 REPAIR MANUAL
 MANUAL DE REPARACIONES
 MANUALE DI RIPARAZIONE

N° 559/2

OPERATIONS
 ARBEITSVORGÄNGE
 OPERATIONS
 OPERACIONES
 OPERAZIONI

AM 3 330-00

AMI 8

BERLINE (AM série JA)
 BREAK (AM série JB)
 BREAK COMMERCIAL (AM série JB)
 BREAK SERVICE (AM série JC)

9-1969

BOITE DE VITESSES - GETRIEBE - GEARBOX - CAJA DE VELOCIDADES - SCATOLA CAMBIO

COUPE HORIZONTALE
 DRAUFSICHT
 HORIZONTAL SECTION
 SECCIÓN HORIZONTAL
 SEZIONE ORIZZONTALE

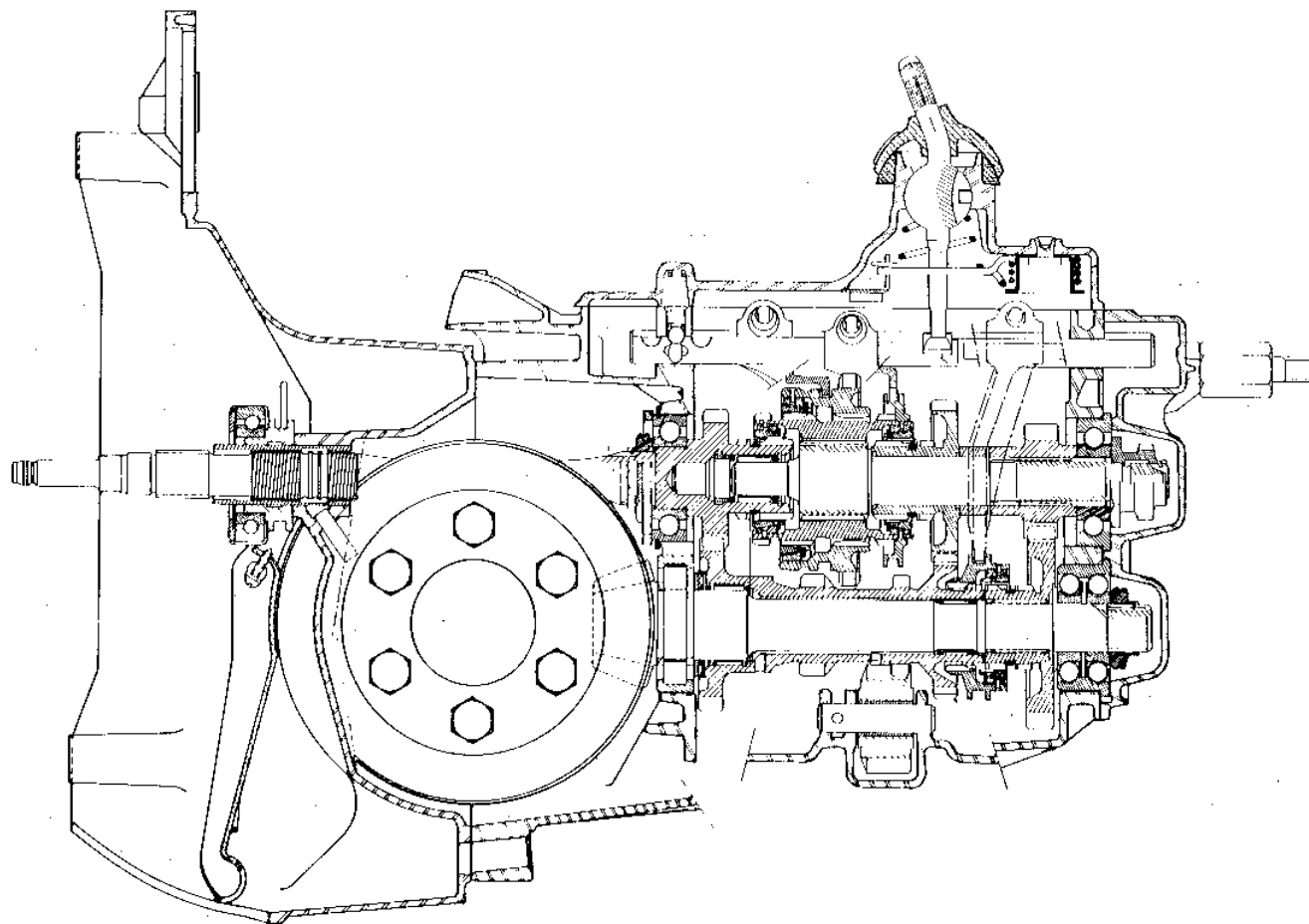

A. 22-7

BOITE DE VITESSES
(suite)

GETRIEBE
(Forts.)

GEARBOX
(continued)

CAJA DE VELOCIDADES
(continuación)

SCATOLA CAMBIO
(seguito)

COUPE TRANSVERSALE
QUERSCHNITT
CROSS SECTION
SECCION TRANSVERSAL
SEZIONE TRASVERSALE

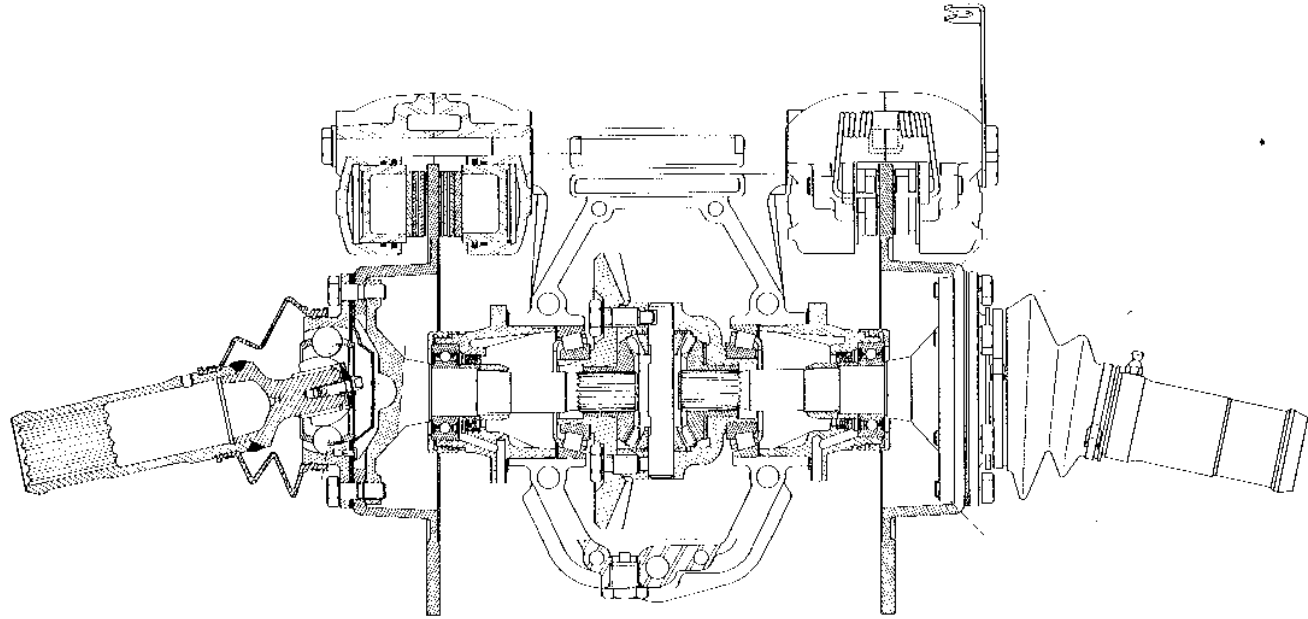

1	MANUEL DE REPARATIONS REPARATURHANDBUCH REPAIR MANUAL MANUAL DE REPARACIONES MANUALE DI RIPARAZIONE	OPERATIONS ARBEITSVORGÄNGE OPERATIONS OPERACIONES OPERAZIONI	AMI 8 BERLINE (AM série JA) BREAK (AM série JB) BREAK COMMERCIAL (AM série JB) BREAK SERVICE (AM série JC) 9 - 1969 	DIFFERENTIEL JEUX DE FONCTIONNEMENT - Satellites (au point de jeu mini) - Planétaires (au point de jeu mini) COUPLES DE SERRAGE - Bague écrou de blocage de roulement d'arbre de différentiel - Ecrou de serrage de roulement d'arbre de différentiel - Ecrous d'assemblage de palier de différentiel et plateau de frein - Vis de fixation de la couronne COUPLE CONIQUE Jeu entre dents CARTER D'EMBRAYAGE Bossages d'assemblage : Faux plan maxi	DIFFERENTIAL FUNKTIONSSPIEL - Satellitenräder (Mindestspiel) - Planetenräder (Mindestspiel) ANZUGSMOMENTE - Ringmutter z. Blockierung d. Kugellagers der Differentialwelle - Mutter z. Befestigung des Kugellagers auf der Differentialwelle - Muttern zur Befestigung d. Lagergehäuses u. der Bremstragplatte - Befestigungsschrauben für Tellerad TELLER-KEGELRAD Zahnflankenspiel KUPPLUNGSGEHÄUSE Auflagepunkte : Max. Auflageunterschied	DIFFERENTIAL OPERATIONAL CLEARANCES - Satellites (at position of minimum clearance) - Backlash (at position of minimum clearance) TIGHTENING TORQUES - Differential shaft bush-nut - Differential shaft nut - Nuts securing bearings and brake back-plates - Screws securing crown wheel CROWN WHEEL AND PINION Back-lash CLUTCH HOUSING Assembly bosses : Max. déviation from flat	- DIFERENCIAL JUEGOS DE FUNCIONAMIENTO - Satélites (En el punto de juego mínimo) - Planetarios (en el punto de juego mínimo) PARES DE APRIETE - Casquillo tuerca de apriete del rodamiento del árbol de diferencial - Tuerca de fijación del rodamiento del árbol de diferencial - Tuercas de ensamblado del cojinete de diferencial con el plato de frenos - Tornillo de fijación de la corona GRUPO CÓNICO Juego entre dientes CARTER DE EMBRAGUE Abultamientos de ensamblado : Falso plano máxi.	DIFFERENZIALE GIOCO DI FUNZIONAMENTO - Satelliti (al punto di gioco minimo) - Planetari (al punto di gioco minimo) COPPIE DI SERRAGGIO - Ghiera di bloccaggio cuscinetto del semiasse del differenziale - Dado di serraggio cuscinetto del semiasse del differenziale - Dadi di assemblaggio supporti semiasse del differenziale e piatto portaceppi freno - Viti di fissaggio corona COPPIA CONICA Gioco d'ingranamento CAMPANA FRIZIONE Rilievi di assemblaggio : Falsa pianeità massima	0,10 mm 0,10 mm 8 mkg (57 ½ FT lbs) 14 à 16 mkg (102 to 116 FT lbs) 3,8 à 4,2 mkg (28 to 30 FT lbs) 7 à 8 mkg (51 to 58 FT lbs) 0,14 à 0,18 mm 0,10 mm
---	--	---	--	---	---	---	---	--	---

MANUEL DE REPARATIONS
REPARATURHANDBUCH
REPAIR MANUAL
MANUALE DE REPARACIONES
MANUALE DI RIPARAZIONE

N° 559/2

OPERATIONS
ARBEITSVORGÄNGE
OPERATIONS
OPERACIONES
OPERAZIONI

AM3. 330 - 00
AM3. 330 - 3
AM3. 330 - 6

AMI 8

BERLINE (AM série JA)
BREAK (AM série JB)
BREAK COMMERCIAL (AM série JB)
BREAK SERVICE (AM série JC)
9 - 1969

COUPLE CONIQUE - TELLER-KEGELRAD - CROWN WHEEL AND PINION - GRUPO CONICO - COPPIA CONICA

Axe de différentiel
Differentialachse
Centre line of differential
Eje de diferencial
Asse del differenziale

Jeu d'entre dents
Zahnflankenspiel
Backlash
Juego entre dientes
Gioco d'ingranamento

0,14 à
0,18 mm

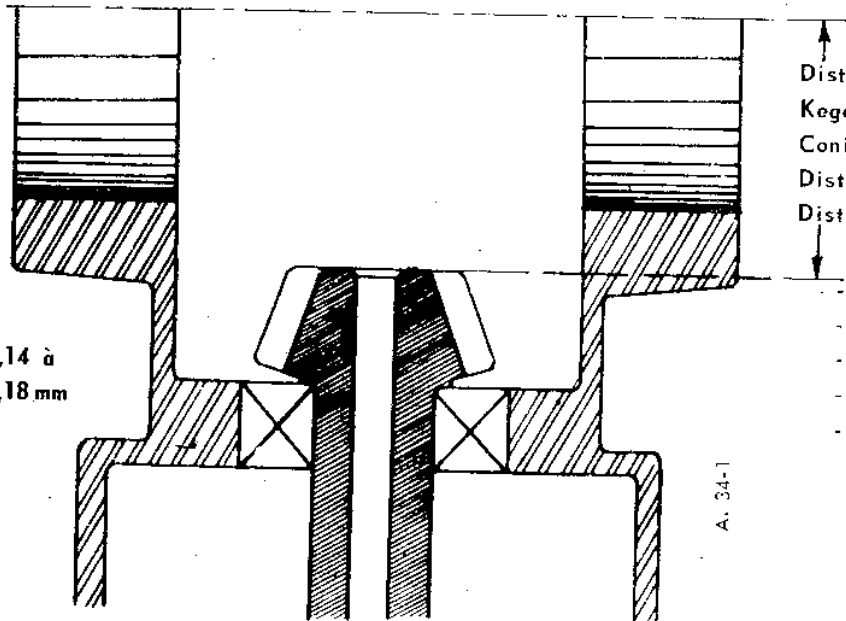

Distance conique
Kegelradtiefe
Conical distance
Distancia cónica
Distanza conica

- Numéro d'appariement
- Kontrollnummern
- Matching number
- Número de emparejamiento
- Numero di accoppiamento

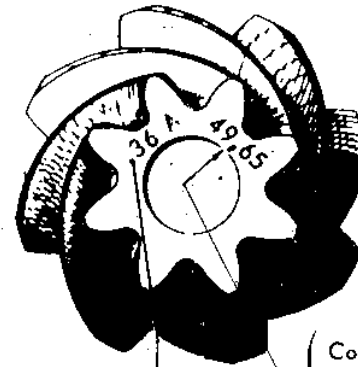

Pignon
Kegelrad
Pinion
Piñon
Pignone

Cote de réglage de ce pignon
Einstellmaß d. Kegelradtiefe
Meshing dim «d» of this pinion
Cota de reglaje de este piñon
Quota di regolazione di questo pignone

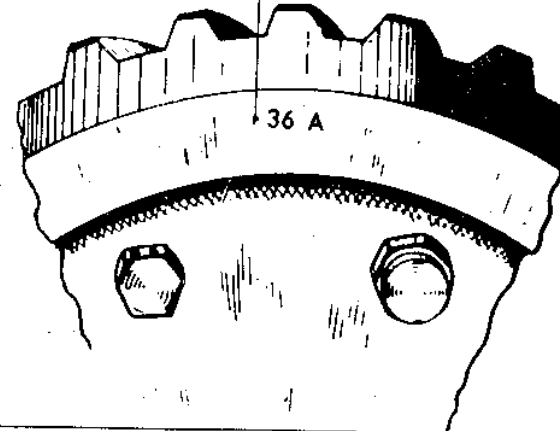

Couronne
Tellerrad
Crownwheel
Corona
Corona

- NOTE : La différence entre deux mesures (faites à 90° environ) ne doit pas dépasser 0,1 mm.
- ANM : Der Unterschied zwischen zwei Messungen (bei ca 90°) darf 0,1 mm nicht überschreiten
- NOTE : The difference between 2 measurements (taken at about 90°) must not exceed 0,1 mm
- OBSERVACION : La diferencia entre dos medidas (hechas a 90° aprox.) no debe ser superior de 0,1 mm
- NOTA : La differenza tra due misure (rilevate a 90° circa) non deve superare 0,1 mm

1	MANUEL DE REPARATIONS REPARATURHANDBUCH REPAIR MANUAL MANUAL DE REPARACIONES MANUALE DI RIPARAZIONE	N° 559/2	OPERATIONS ARBEITSYORGÄNGE OPERATIONS OPERACIONES OPERAZIONI	AM3. 372 - 1	AMI 8	BERLINE (AM série JA) BREAK (AM serie JB) BREAK COMMERCIAL (AM serie JB) BREAK SERVICE (AM serie JC)	9 - 1969
TRANSMISSIONS	GELENKWELLEN	DRIVE - SHAFTS.	TRANSMISIONES	TRASMISSIONI	<p>35 à 40 mkg (250 to 290 ft.lbs)</p> <p>5 à 6 mkg (36 to 43 ft.lbs)</p> <p>4,5 à 6 mkg (33 to 43 ft.lbs)</p> <p>RETINAX AM</p>		
Transmissions à billes	Gelenkwellen mit Kugelgelenk	Drive-shafts with ball-type universals.	Transmisión de bolas	Trasmissioni a sfera			
COUPLES DE SERRAGE	ANZUGSMOMENTÉ	TIGHTENING TORQUES	PARES DE APRIETE	COPPIE DI SERRAGGIO			
- Ecrou de fixation de transmission sur moyeu	- Mutter z.Befest der Gelenkwelle auf der Nabe	- Nut securing drive-shafts on hub	- Tuerca de fijación de la transmisión al buje	Dado di fissaggio trasmissione sul mozzo			
- Vis de fixation de transmission et de tambour	- Schraube z.Befestigung der Gelenkwelle und der Trommel.	- Screws securing drive shafts and drum. (ball type universals)	- Tornillos de fijación de transmisión y tambor	- Vite di fissaggio trasmissione o tamburo			
- Ecrous de fixation de roues	- Muttern zur Radbefestigung	- Wheel nuts	- Tuercas de fijación de ruedas	- Dadi di fissaggio ruote			
- Graissage joint homocinétique à billes.	- Schmierung d.Schiebestücks für die Kugelgelenkwelle	- Lubrication constant velocity joint, ball type.	- Engrase juntas homocinéticas de bolas	- Ingrassaggio giunto omocinetico a sfera			
NOTE : Toutes les pièces constituant la transmission étant appariées entre elles, il n'est pas possible de procéder à la réparation de ces transmissions. Il faut opérer par échange de la transmission complète (côté boîte ou côté pivot).	ANM.: Da alle Teile der Gelenkwelle aufeinander abgestimmt sind, ist es nicht möglich, diese Gelenkwellen zu reparieren. Die gesamte Gelenkwelle muss ausgewechselt werden. (auf Getriebe oder Radnabenseite).	NOTE : All the parts constituting the drive-shaft being paired it is not possible to repair these drive-shafts, change the whole drive-shaft (gearbox end or swivel end).	OBSERVACION : Estando enparejadas todas las piezas que constituyen la transmisión no se puede reparar esta, hay que proceder por sustitucion de la transmisión completa (lado caja de cambio o lado pivote)	NOTA : Poiché tutti i pezzi costituenti la trasmissione sono accoppiati tra di loro, non e' possibile procedere alla riparazione di queste trasmissioni. Si deve procedere alla sostituzione della trasmissione completa (lato scatola cambio o lato pivot).			

1	MANUEL DE REPARATIONS REPARATURHANDBUCH REPAIR MANUAL MANUAL DE REPARACIONES MANUALE DI RIPARAZIONE	N° 559/3	OPERATIONS ARBEITSVORGÄNGE OPERATIONS OPERACIONES OPERAZIONI	AM3. 410 - 00	AMI 8	BERLINE (AM série JA) BREAK (AM série JB) BREAK COMMERCIAL (AM série JB) BREAK SERVICE (AM série JC) 9 - 1969 -I→
ESSIEU AVANT	VORDERACHSE	FRONT AXLE	EJE DELANTERO	ASSALE ANTERIORE		
CARROSSAGE :	RADSTURZ :	CAMBER :	CAIDA INCLINACION DE LA RUEDA :	INCLINAZIONE :		
Roues en ligne droite	Räder b.Geradeausfahrt.	Wheels centralised	Ruedas en línea recta	Ruote in posizione di marcia rettilinea	1° + 45' - 25'	
Roues braquées à fond	Räder eingeschlagen	Wheels «full lock»	Ruedas giradas a fondo	Ruote sterzate a fondo	9° 30 ± 1° 20'	
CHASSE	NACHLAUF	CASTER ANGLE	AVANCE DE LA RUEDA	INCIDENZA		
(non controlable sur voiture)	(nicht kontrollierbar am Fahrzeug)	(cannot be checked on vehicle)	(no controlable sobre el coche)	(non controllabile su vettura)	15°	
PARALLELISME : (ouverture des roues)	SPUR (Öffnet nach vorn)	PARALLELISM (Toe - out)	PARALELISMO (Apertura de ruedas)	PARALLELISMO (Apertura delle ruote)	1 à 3 mm ($\frac{3}{64}$ to $\frac{1}{8}$ in)	
ANGLE DE BRAQUAGE	EINSCHLAGWINKEL DER LENKUNG	ANGLE OF LOCK	ANGULO DE VIRAJE	ANGOLO DI STERZATA	35°	
BRAS ET TRAVERSE	SCHWINGARM UND TRAVERSE	ARMS AND CROSS-MEMBER	BRAZOS Y TRAVIESA	BRACCIO E TRAVERSA		
- Serrage vis de fixation traverse d'essieu (Face et filets graissés)	Anzugsmom.d.Schrauben z.Befest.d.Achstraverse (Fläche und Gewinde geschmiert)	Tightening of screws securing axle cross-member (Face and threads greased)	Apriete tornillo de fijación traviesa de eje (Frente e hilos de rosca engrasados)	- Serraggio vite di fissaggio traversa assale (Faccia e filetti ingrassati)	4 à 5 mkg (29 to 36 ft lbs)	
- Serrage écrou crenelé de blocage de roulement de bras sur traverse	Anzugsmom.d.Kronenmutter z.Befestigung des Schwingarms	- Tightening slotted nut locking bearing on cross-member arm	- Apriete tuerca almenada de bloqueo de rodamiento de brazo sobre traviesa	- Serraggio dado a corona di bloccaggio cuscinetto del braccio sulla traversa	5 mkg (36 ft lbs)	
- Faux rond traverse (Portée des roulements)	- Schlag d.Traverse (Auflager d.Rollenlag.)	- Eccentricity (bearing surface)	- Falso redondo traviesa (asiento de los rodamientos)	- Falsa concentricità traversa (portata dei cuscinetti)	0,2 mm maxi (massimo)	
- Contrôle du bras (sur montage 630-51/46 Ex MR 3745) les deux longueurs de contrôle doivent être égales.	Schwingarm prüfen (Vorrichtung MR 630-51/46 Früher MR 3745) beide Längen müssen gleich sein bis auf.	- Checking arm (on fixture 630-51/46 EX MR 3745) the two checking lengths must be equal to within	- Control del brazo (sobre el montaje 630-51/46 EX MR 3745) las dos cotas de control deben ser iguales.	- Controllo del braccio (su montaggio 630-51/46 EX MR 3745) le due lunghezze di controllo devono essere uguali.	à 10 mm près (circa)	

MANUEL DE REPARATIONS
REPARATURHANDBUCH
REPAIR MANUAL
MANUAL DE REPARACIONES
MANUALE DI RIPARAZIONE

N° 559/3

OPERATIONS
ARBEITSVORGÄNGE
OPERATIONS
OPERACIONES
OPERAZIONI

AM3. 410-00
AM3. 410-3
AM3. 412-1
AM3. 413-1

AMI 8

BERLINE (AM série JA)
BREAK (AM série JB)
BREAK COMMERCIAL (AM série JB)
BREAK SERVICE (AM série JC)

9 - 1969

ESSIEU AVANT - VORDERACHSE - FRONT AXLE - EJE DELANTERO - ASSALE ANTERIORE
(suite) (Forts.) (continued) (continuación) (seguito)

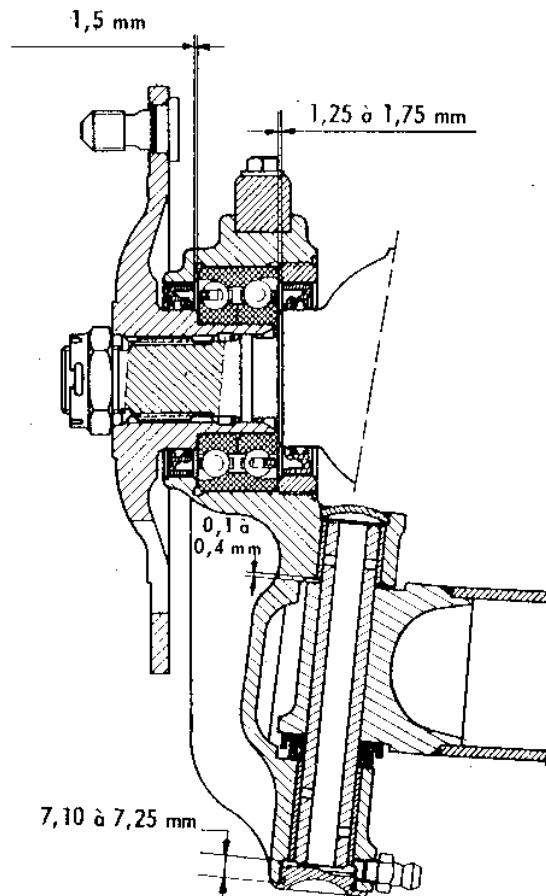

A. 41-6

3	PIVOT	RADNABE	SWIVEL	PIVOTE	PIVOT	
	Retrait des bagues d'étanchéité par rapport à la bague extérieure de roulement de moyeu.	Abstand des Dichtringes der Nabe im Verhältnis zum Aussenring des Kugellagers für die Nabe	Inset of sealing bushes in relation to outer bush of hub bearing	Retracción de los retenes en relación con el casquillo exterior de rodamiento de buje	Rientranza delle boccole di tenuta rispetto alla boccola esterna del cuscinetto del mozzo	1,5 mm
	Jeu entre pivot et bras	Spiel zwischen Radnabe u. Schwingarm	Clearance between swivel and arm	Juego entre pivote y brazo	Gioco tra pivot e braccio	0,1 à 0,4 mm
	Retrait de la partie inférieure de l'axe par rapport au pivot	Rückstand d. unter. Teils der Achse im Verhältnis z. Radnabe	Inset of lower part of pin in relation to swivel	Retracción de la parte inferior del eje en relación con el pivote	Rientranza della parte inferiore del perno rispetto al pivot	7,10 à 7,25 mm
	COUPLES DE SERRAGE	ANZUGSMOMENTE	TIGHTENING TORQUES	PARES DE APRIETE	COPPIE DI SERRAGGIO	
	Bague écrou du roulement de moyeu.	Ringmutter des Radnabenlagers	Shrouded nut on hub bearing.	Casquillo tuerca del rodamiento de buje	Ghiera del cuscinetto del mozzo	35 à 40 mkg (250 to 290 ft.lbs.)
	Ecrou de fusée	Achsmutter	Stub-axle nut	Tuerca de mangueta	Dado del fusello	35 à 40 mkg (250 to 290 ft.lbs.)
	Vis du levier d'accouplement sur pivot	Schrauben der Spurstangenhebel	Screw for swivel coupling-lever	Tornillo bieleta de acoplamiento sobre pivote	Vite della leva d'accoppiamento sul pivot	1,5 à 2 mkg (11 to 14 ft.lbs.)
	Bouchon inférieur de pivot	Unterer Stopfen der Radnabe	Lower plug on swivel	Tapón inferior de pivote	Tappo inferiore del pivot	2 mkg (14 1/4 ft.lbs.)
	Ecrous de fixation de batteurs	Befestigungsmuttern der Trägheitsdämpfer	Nuts securing inertia damper	Tuercas de fijación de batidores	Dadi di fissaggio battenti ad inerzia	6 mkg (43 ft.lbs.)
	Ecrous de roues	Radmuttern	Wheel nuts	Tuercas de ruedas	Dadi delle ruote	4,5 à 6 mkg (33 to 43 ft.lbs.)

1	MANUEL DE REPARATIONS REPARATURHANDBUCH REPAIR MANUAL MANUAL DE REPARACIONES MANUALE DI RIPARAZIONE	N° 559/3	OPERATIONS ARBEITSVORGÄNGE OPERATIONS OPERACIONES OPERAZIONI	AM3. 420-00 AM3. 422-0	AMI 8	BERLINE (AM série JA) BREAK (AM série JB) BREAK COMMERCIALE (AM série JB) BREAK SERVICE (AM série JC) 9 - 1969
ESSIEU ARRIERE	HINTERACHSE	REAR AXLE	EJE TRASERO	ASSALE POSTERIORE		
CARROSSAGE	RADSTURZ	CAMBER	INCLINACION DE LA RUEDA	INCLINAZIONE	0° 1 30' 0	
PARALLELISME	SPUR	PARALLELISM	PARALELISMO	PARALLELISMO	0 ± 4 mm (0 to 3/16 in)	
BRAS ET TRAVERSE	SCHWINGARM UND TRAVERSE	ARMS AND CROSS-MEMBERS	BRAZOS Y TRAVIESA	BRACCIO E TRAVERSA		
Vis de fixation traverse (Face et filets graissés)	-Anzugsmoment der Traversenschrauben (Fläche und Gewinde geschmiert)	Screws securing cross-members (Faces and threads greased)	Tornillos de fijación traviesa. (Frente e hilos de rosca engrasados)	Vite di fissaggio traversa (Faccia e filetti ingrassati)	4 à 5 mkg (29 to 36 ft.lbs.)	
Ecrou crenelé de fixation de roulement de bras sur traverse	Kronenmutt.z.Befestig. d. Rollenlagers für den Schwingarm	Slotted nut securing bearing on cross-member arm.	Tuerca almenada de fijación de rodamiento de brazo sobre traviesa	Dado a corona di fissaggio cuscinetto del braccio sulla traversa.	5 mkg (36 ft.lbs.)	
Faux rond de traverse (portée des roulements)	- Schlag der Traverse (Auflager d.Rollenlager)	Eccentricity of cross-member (bearing surface)	Falso redondo de traviesa (asiento rodamientos)	Falsa concentricita della traversa (portata dei cuscinetti)	0,1 mm maxi	
CONTROLE DU BRAS (sur montage 630-51/46 ex-MR 3745)	SCHWINGARMKONTROLLE (auf Vorrichtung 630-51/46 früher MR 3745)	CHECKING THE ARMS (on fixture 630-51/46 ex.MR.3745)	CONTROL DEL BRAZO (en montaje 630-51/46 ex : MR : 3745)	CONTROLLO DEL BRACCIO (su montaggio 630-51/46 ex MR 3745)		
PINCEMENT : Différence des 2 hauteurs - La plus grande hauteur doit se trouver côté axe de fusée.	VORSPUR : Unterschied der beiden Höhen. Die grössere Höhe muss sich auf der Seite der Schwingarmachse befinden	TOE IN : Difference of two heights the greater height must be on the stub axle-side	CONVERGENCIA : Diferencia de las dos alturas. La altura mayor debe estar del lado del eje de mangueta.	CONVERGENZA : Differenza delle due altezze - L'altezza maggiore deve trovarsi lato perno fusello.	0 à 1,2 mm	

MANUEL DE REPARATIONS
 REPARATURHANDBUCH
 REPAIR MANUAL
 MANUAL DE REPARACIONES
 MANUALE DI RIPARAZIONE

N° 559/3

OPERATIONS
 ARBEITSVORGÄNGE
 OPERATIONS
 OPERACIONES
 OPERAZIONI

AM3-420-00

AM3-422-0

AM! 8

BERLINE (AM série JA)
 BREAK (AM série JB)
 BREAK COMMERCIAL (AM série JB)
 BREAK SERVICE (AM série JC)
 9-1969
 →

ESSIEU ARRIERE - HINTERACHSE - REAR AXLE - EJE TRASERO - ASSALE POSTERIORE

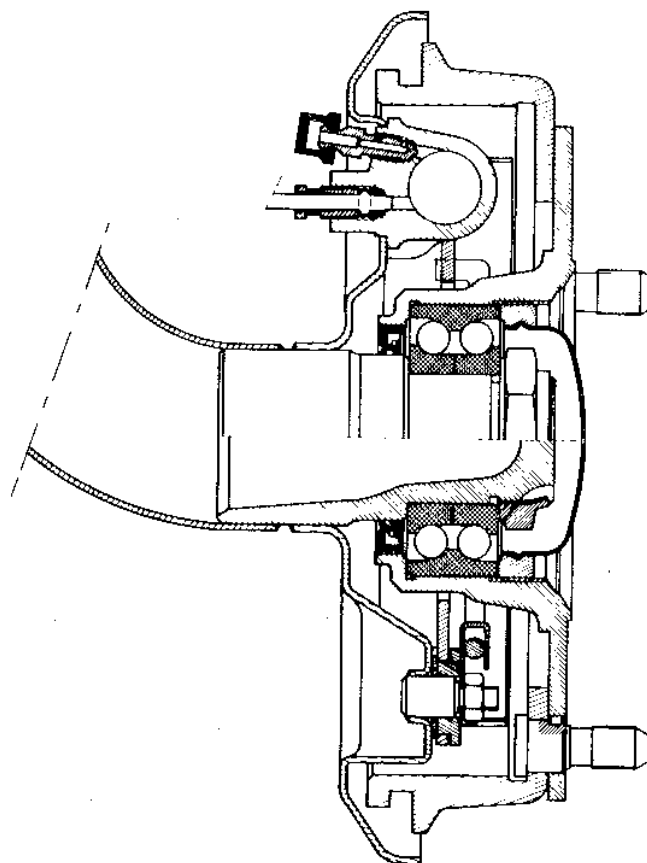

3	<p>CARROSSAGE</p> <p>Différence des deux hauteurs</p> <p>La plus petite hauteur doit se trouver côté chape porte-couteau</p> <p>MOYEU TAMBOUR</p> <p>Retrait garniture d'étanchéité par rapport colle-rette d'appui roulement.</p> <p>COUPLES DE SERRAGE</p> <p>Ecrou de blocage de roulement de moyeu.</p> <p>Bague écrou de roulement de moyeu.</p> <p>Ecrou raccord de frein</p> <p>Ecrous de roues</p> <p>Ecrous de fixation de batteur</p> <p>Ecrous de fixation d'amortisseur</p>	<p>RADSTURZ</p> <p>Unterschied der beiden Höhen</p> <p>Die kleinere Höhe muss sich auf der Seite des Gabelstückes befinden</p> <p>RADNABE</p> <p>Rückstand der Dichtung im Verhältnis zum Aussenring des Kugellagers</p> <p>ANZUGSMOMENTE</p> <p>- Achsmutter</p> <p>- Ringmutter der Radnabe</p> <p>- Verbindungsmutter der Bremsleitungen</p> <p>- Radmuttern</p> <p>- Befestigungsmuttern der Trägheitsdämpfer</p> <p>- Befestigungsmuttern der Stossdämpfer</p>	<p>CAMBER</p> <p>Difference of two heights</p> <p>The smaller height must be towards the knife-edge bracket</p> <p>HUB AND BRAKE DRUM</p> <p>Inset of seal in relation to bearing thrust collar</p> <p>TIGHTENING TORQUES</p> <p>Nut locking hub bearing</p> <p>Shrouded nut on hub bearing</p> <p>Brake union nut</p> <p>Wheel nuts</p> <p>Nuts securing inertia damper</p> <p>Nuts securing shock absorber</p>	<p>INCLINACION DEL MUÑON</p> <p>Diferencia de las dos alturas</p> <p>La altura menor debe estar del lado de la chapa porta cuchillo.</p> <p>BUJE TAMBOR</p> <p>Retracción retén de estanqueidad en relación cuello asiento rodamiento</p> <p>PARES DE APRIETE</p> <p>Tuerca de bloqueo del rodamiento de buje</p> <p>Casquillo tuerca del rodamiento de buje</p> <p>Tuerca racor de freno</p> <p>Tuercas de ruedas</p> <p>Tuercas de fijación de batidores</p> <p>Tuercas de fijación de amortiguador</p>	<p>INCLINAZIONE</p> <p>Differenza delle due altezze</p> <p>L'altezza minore deve trovarsi lato attacco porta-coltello</p> <p>MOZZO TAMBURO</p> <p>Ricntranza guarnizione di tenuta rispetto al collarino d'appoggio cuscinetto</p> <p>COPPIE DI SERRAGGIO</p> <p>- Dado di bloccaggio cuscinetto del mozzo</p> <p>- Ghiera del cuscinetto del mozzo</p> <p>- Dado raccordo del freno</p> <p>- Dadi delle ruote</p> <p>- Dadi di fissaggio battente ad inerzia</p> <p>- Dadi di fissaggio ammortizzatore</p>	<p>0 à 3,5 mm (0 to 1/8 in)</p> <p>1¹/₀ 0,5 mm</p> <p>27 à 30 mkg (195 to 215 ft.lbs.)</p> <p>35 à 40 mkg (250 to 290 ft.lbs.)</p> <p>0,6 à 0,8 mkg (4.3 to 5.8 ft.lbs.)</p> <p>4,5 à 6 mkg (33 to 43 ft.lbs.)</p> <p>6 mkg (43 ft.lbs.)</p> <p>3,6 mkg (26 ft.lbs.)</p>
---	--	--	---	--	--	--

4	MANUEL DE REPARATIONS REPARATURHANDBUCH REPAIR MANUAL MANUAL DE REPARACIONES MANUALE DI RIPARAZIONE	N° 559/3	OPERATIONS ARBEITSVORGÄNGE OPERATIONS OPERACIONES OPERAZIONI	AM3 420-00 a	AMI 8	BERLINE (AM série JA) BREAK (AM série JB) BREAK COMMERCIAL (AM série JB) BREAK SERVICE (AM série JC) 9-1969
---	---	----------	--	--------------	-------	--

ESSIEU ARRIERE (suite)	HINTERACHSE (forts.)	REAR AXLE (continued)	EJE TRASERO (continuación)	ASSALE POSTERIORE (seguito)	
Garantie entre les spires du tube d'alimentation et la traverse g Diamètre extérieur des ca- nalisations de freins Diamètre intérieur des garnitures joint Diamètre des raccords de canalisation Serrage des écrous de fixation des pattes de tube d'alimentation Serrage de la vis de fixa- tion du raccord trois voies Serrage des écrous-raccord de canalisations de freins	Spiel zwischen Wicklungen des Zuführrohres und Traverse g = Aussen - ϕ der Brems- leitungen Innen - ϕ der Dichtgarni- turen Durchmesser der Verbin- dungen der Leitung Anzugsmomente der Muttern zur Befestigung der Laschen für das Zuführrohr Anzugsmoment der Schraube zur Befestigung der Dreiwege- Verbindungsmuttern für die Bremsleitungen	Clearance "g" between the turns of the brake pipe and the cross member g = O.D. of brake pipes I.D. of pipe seals Diameter of unions for piping Tighten nuts securing feed pipe attachment clips, to Tighten screw fixing three- way union, to Tighten union screws on brake pipes, to	Garantía entre el tubo de alimentación y la traviesa g = Diámetro exterior de los canalizaciones de los frenos Diámetro interior de las tubitos juntas Diámetro de los racores de las canalizaciones Apriete de las tuercas de fijación de las patillas de los tubos de alimentación Apriete del tornillo de fija- ción del racor tres vocas Apriete de las tuercas racor- de las canalizaciones de los	Gioco tra le spire del tubo di alimentazione e la traversa g = Diametro esterno delle canalizzazioni dei freni Diametro interno delle guarnizioni di raccordo Diametro dei raccordi delle canalizzazioni Serraggio dei dadi di fissaggio delle staffe del tubo di alimentazione Serraggio della vite di fis- saggio del raccordo a tre vie Serraggio dei dadi-raccordo della canalizzazioni dei freni	6 mm mini 3,5 mm 4 mm 8-125 1 m.kg (7 ft. lbs) 2 m.kg (14 ft. Lbs) 0,8 à 0,9 m.kg (5,8 ts 6,5 ft. Lbs)

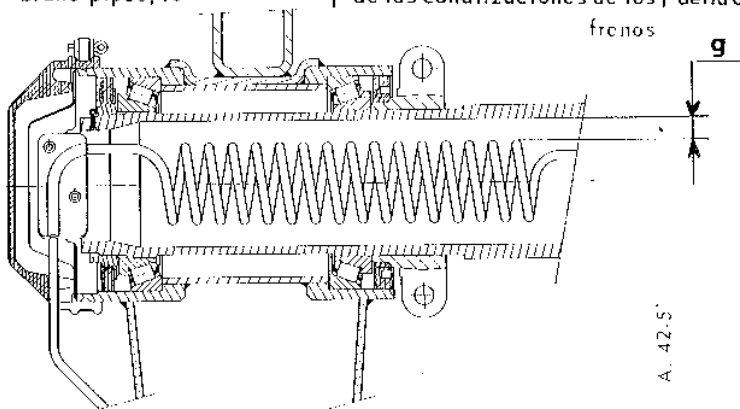

1 MANUEL DE REPARATIONS REPARATURHANDBUCH REPAIR MANUAL MANUAL DE REPARACIONES MANUALE DI RIPARAZIONE		N° 559/3		OPERATIONS ARBEITSVORGÄNGE OPERATIONS OPERACIONES OPERAZIONI		AM3. 430-00 AM3. 434-3	AMI 8	BERLINE (AM série JA) BREAK (AM série JB) BREAK COMMERCIAL (AM série JB) BREAK SERVICE (AM série JC) 9 - 1969 →			
SUSPENSION POT DE SUSPENSION CARTER DE POT (Tole de 0,9 mm) ⌀ Extérieur = Longueur L1 = REPÈRE (Sens de montage) AV : (sur enveloppe) RESSORTS : ⌀ du fil = Ressort avant (Enroulement à gauche) Hauteur libre maxi ⌀ du fil = Ressort arrière (Enroulement à droite) Hauteur libre maxi TIRANTS Longueur totale = - tirant avant - tirant arrière EMBOUTS DE REGLAGE Longueur totale Embout avant Embout arrière BUTEES ELASTIQUES : -avant -arrière		FEDERUNG FEDERUNGSTOPF GEHÄUSE (Blech 0,9 mm) Aussen - ⌀ Länge L1 Markierung (Einbauricht) AV : (Auf Gehäuse) FEDERN Draht - ⌀ = Vordere Feder (Linkswicklung) Draht - ⌀ Hintere Feder (Rechtswicklung) STREBEN Gesamtlänge - Vordere Strebe - Hintere Strebe EINSTELL ENDEN Gesamtlänge = Vorderes Endstück Hinteres Endstück ELASTISCHE ANSCHLÄGE -vorn -hinten		SUSPENSION SUSPENSION CYLINDER CASING (Sheet metal 0,9 mm) External ⌀ Length L1 = MARKING (Direc. of fitting) AV : (on casing) front SPRINGS Wire ⌀ Front spring (Left hand coil) Wire ⌀ Rear spring (Right hand coil) TIERODS Total length = - front tierod - rear tierod ADJUSTING END PIECES Total length = Front end pièce Rear end pièce RUBBER STOPS : -front -rear		SUSPENSION TUBO DE SUSPENSION CARTER DEL TUBO (chapa de 0,9 mm) ⌀ Exterior = Longitud L1 PUNTO DE REFERENCIA (Sentido de montaje) AV : (sobre el tubo) MUELLES ⌀ del hilo muelle delantero (Enrollado a izquierda) ⌀ del hilo muelle trasero (Enrollado a derecha) TIRANTES Longitud total - tirante delantero - tirante trasero TERMINALES DE REGLAJE Longitud total Terminal delantero Terminal trasero TOPES ELASTICOS : -delantero -trasero		SOSPENSIONE CILINDRO DI SOSPENSIONE CARTER DEL CILINDRO (Lamiera da 0,9) ⌀ Esterno Lunghezza L1 = RIFERIMENTO (Senso di montaggio) AV:(sul carter) MOLLE ⌀ del filo = molla ant. (avvolgimento sinistro) ⌀ del filo molla post. (avvolgimento destro) TIRANTI Lunghezza totale - tirante ant - tirante post. TERMINALI DI REGO-LAZIONE Lunghezza totale Terminale ant. Terminale post. REGGISPINTA ELASTICI : -ant. -post.		BERLINE AM3 136 mm (5,36 in) 510 mm (20,08 in) 18,2 mm 160 mm 18,6 mm 222,5 mm 600 mm 642 mm 197 mm (7 3/4 in) 75 x 30 75 x 30	BREAKS AMF3 - AMC3 136 mm (5,36 in) 510 mm (20,08 in) 19 mm 195 mm 19 mm 243 mm 618 mm 642 mm 197 mm (7 3/4 in) 75 x 30 110 x 30

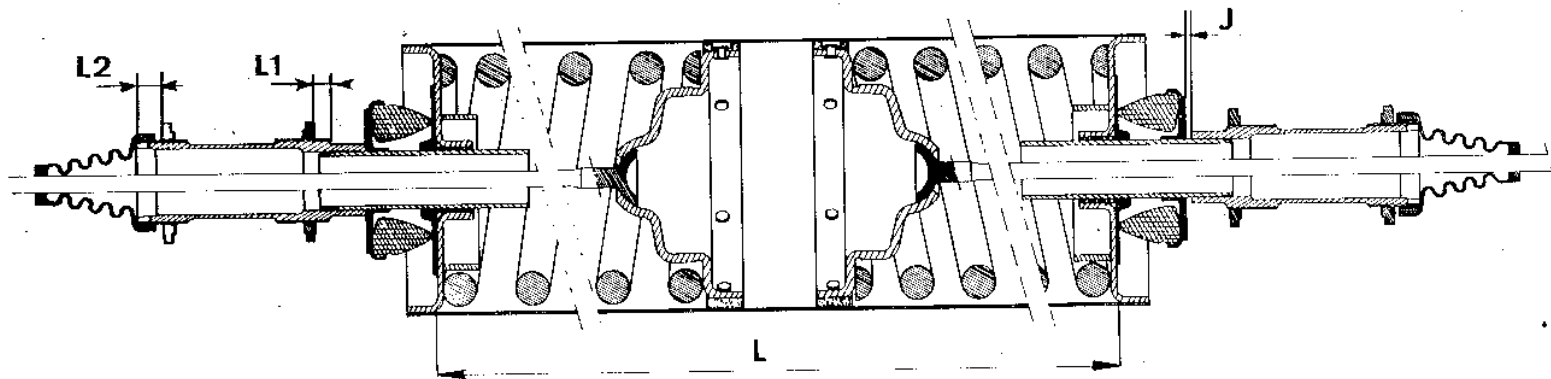

A 12-50

HAUTEURS - HÖHEN - HEIGHTS - ALTURAS - ALTEZZE -								
PNEUS REIFENTYP TYRES NEUMATICOS PNEUMATICI	PRESSIONS DE GONFLAGE LUFTDRÜCKE INFLATION PRESSURES. PRESIONES DE INFLADO PRESSIONI DI GONFIAGGIO		EN KG/cm ²		HAUTEURS DE CAISSE (Sous le moyeu des bras) HÖHENEINSTELLUNG (Unterkante Schwingarmnabe) HEIGHT OF BODY (Under arm hub) ALTURA DE CARROCERIA (Bajo el buje de los brazos) ALTEZZE DELLA SCOCCA (Sotto il mozzo dei bracci)			
	AVANT VORN FRONT	DEL. ANT.	ARRIERE HINTEN REAR	TRAS. POST.	BERLINE AM3		BREAKS - AMF3 - AMC3	
BERLINE AM3 125 - 380 X	1,800 (26 psi)		1,800 (26 psi)		AVANT VORN FRONT DEL. ANT.	ARRIERE HINTEN REAR TRAS POST.	AVANT VORN FRONT DEL. ANT.	ARRIERE HINTEN REAR TRAS POST.
BREAKS 135 - 380 X	1,400 (20 psi)		1,700 (25 psi)		190 ± 2,5 mm (7 1/2 ± 1/16 in)	280 ± 2,5 mm (11 ± 1/16 in)	195 ± 2,5 mm (7 11/16 ± 1/16 in)	290 ± 2,5 mm (11 7/16 ± 1/16 in)

MANUEL DE REPARATIONS
REPARATURHANDBUCH
REPAIR MANUAL
MANUAL DE REPARACIONES
MANUALE DI RIPARAZIONE

N° 559-3

OPERATIONS
ARBEITSVORGÄNGE
OPERATIONS
OPERACIONES
OPERAZIONI

AM3-430-00
AM3-430-0
AM3-434-1
AM3-434-3

AMI 8

BERLINE (AM série JA)
BREAK (AM série JB)
BREAK COMMERCIAL (AM série JB)
BREAK SERVICE (AM série JC)
9-1969



SUSPENSION
(suite)

AMORTISSEURS AVANT

(Couleur bleu)

Entr'axe } Tendu
 } Comprimé

AMORTISSEURS ARRIERE

(Couleur gris)

Entr'axe } Tendu
 } Comprimé

Montage : Corps d'amortisseur côté pot de suspension, repère (billage) vers le haut, trous d'évacuation vers le bas

- Serrage des axes d'amortisseur
- Serrage des écrous de fixation d'amortisseur

BATTEURS

Remplissage d'un batteur

Serrage du bouchon de remplissage

Serrage des écrous de fixation

FEDERUNG
(Forts.)

VORDERE STOSSDÄMPFER

(Farbe blau)

Mittelachs-abstand } gezogen
 } gedrückt

HINTERE STOSSDÄMPFER

(Farbe grau)

Mittelachs-abstand } gezogen
 } gedrückt

Einbau : Stossd.-Körper auf Seite Federungstopf Markierung (Erhebung) nach oben Abflusslöcher nach unten.

Anzugsmoment der Stossdämpferachsen
Anzugsmoment der Stossdämpfermuttern

TRÄGHEITSDÄMPFER

Füllung der Trägheitsdämpfer

Anzugsmoment der Füllstopfen

Anzugsmoment der Befestigungsmuttern

SUSPENSION
(continued)

FRONT SHOCK ABSORBERS

(Colour blue)

Centres } In tension
 } Compressed

REAR SHOCK ABSORBERS

(Colour grey)

Centres } In tension
 } Compressed

Assembly : Shock absorber outer housing towards suspension cylinder, mark (ball imprint) uppermost drain holes downwards

Tightening torque for spindles.
Tightening nuts securing shock absorber

INERTIA DAMPERS

Refilling an inertia damper

Tightening filler plug

Tightening screws securing damper

SUSPENSION
(continuación)

AMORTIGUADORES DELANTEROS

(Color Azul)

Entre eje } Tensado
 } Comprimido

AMORTIGUADORES TRASEROS

(Color gris)

Entre eje } Tensado
 } Comprimido

Montaje : Cuerpo de amortiguador lado tubo de suspensión, punto de referencia (granetazo) hacia arriba orificios de evacuación hacia abajo

Apriete de los ejes del amortiguador
Apriete de las tuercas de fijación del amortiguador

BATIDORES

Llenado de un batidor

Apriete del tapón de llenado

Apriete de las tuercas de fijación

SOSPENSIONE
(seguito)

AMMORTIZZATORI ANT.

(Colore blu)

Interasse } Teso
 } Compresso

AMMORTIZZATORI POST.

(Color grigio)

Interasse } Teso
 } Compresso

Montaggio : Corpo dell'amortizzatore lato cilindro di sospensione, riferimento (sferico) verso l'alto, fori d'evacuazione verso il basso

- Serraggio perni ammortizzatore.
- Serraggio dadi di fissaggio ammortizzatore

BATTENTI AD INERZIA

Riempimento di un battente

Serraggio tappo di riempimento

Serraggio dadi di fissaggio

460 mm mini
(18 1/8 in)350 mm maxi
(13 3/4 in)495 mini
(15 1/2 in)
375 maxi
(14 3/4 in)21 mkg
(150 ft. lbs)70 cm³1,3 a 1,7 mkg
(9,4 to 12,3 ft. lbs)6 mkg
(43 ft. lbs)

5	SUSPENSION (suite)	FEDERUNG (Forts.)	SUSPENSION (continued)	SUSPENSION (continuación)	SOSPENSIONE (seguito)	
	BARRE ANTI-ROULIS	STABILISATOR	ANTI-ROLLBAR	BARRA ESTABILIZADORA	BARRA ANTIRULLIO	
	Jeu ou contrainte maximum entre collier et support d'amortisseur	Spiel oder maximale Zusammendrücken zwischen Schelle u. Stossdämpferträger	Clearance or maximum compression between clamp and shock-absorber bracket	Juego o contracción máxima entre abrazadera y soporte del amortiguador	Gioco o forzamento massimo fra collare e supporto ammortizzatore	0,5 mm
	Distance entre marbre et extrémité de la barre	Abstand zw. Richtplatte und Enden d. Stabilisators	Distance between face-plate and end of bar	Distancia entre marmol y el extremo de la barra	Distanza fra piano di riscontro ed estremità della barra	0^{+3}_0 mm
	Si la distance est supérieure à 3 mm, la barre anti-roulis est à remplacer	Wenn der Abstand grösser ist als 3 mm, muss der Stabilisator ausgewechselt werden	If the distance exceeds 3 mm, the anti-roll bar must be replaced	Si la distancia es superior a 3 mm hay que reemplazar la barra estabilizadora	Se la distanza è superiore a 3 mm, la barra antirullio dev'essere sostituita	
	Faux parallélisme Ecart angulaire entre les deux branches : Diamètre	Parallelitätsabweichung Winkelabweichung zw. den beiden Schenkeln : $\phi =$	Parallel to within Angular difference between the two ends : Diameter	Falso paralelismo Diferencia angular entre los dos brazos : Diámetro	Falso parallelismo Scarto angolare fra le due punte : Diámetro	1 % maxi 1° maxi
	COUPLES DE SERRAGE Ecrous de fixation des butées de débattement AV Vis de fixation des colliers de barre anti-roulis Vis de fixation des supports amortisseurs Avant Ecrous de fixation d'amortisseurs arrière Ecrous de fixation des pots de suspension	ANZUGSMOMENTE Schrauben z. Befestigung der vorderen Begrenzungsanschlüge Schrauben z. Befestigung d. Schellen f. den Stabilisator Schrauben z. Befestigung der vorderen Stossdämpferträger Muttern z. Befestigung der hinteren Stossdämpfer Muttern zur Befestigung der Federungstöpfe	TIGHTENING TORQUES Nuts fixing front bump and rebound stops Screws fixing anti-roll bar clamps Screws fixing front shock-absorber brackets Nuts fixing rear shock-absorbers Nuts fixing suspension cylinders	PARES DE APRIETE Tuercas de fijación de los topes de desplazamiento delanteros Tornillos de fijación de las abrazaderas de la barra estabilizadora Tornillos de fijación de los soportes de amortiguadores delanteros Tuercas de fijación de los amortiguadores traseros Tuercas de fijación de los cilindros de suspensión	COPPIE DI SERRAGGIO Dadi di fissaggio degli arresti di escursione ANT. Viti di fissaggio dei collari della barra antirullio Viti di fissaggio dei supporti ammortizzatori ANT. Dadi di fissaggio ammortizzatori posteriori Dadi di fissaggio dei cilindri di sospensione	4 à 5 m.kg (29 to 36 ft lbs) 6 m.kg (43 ft lbs) 4 m.kg (29 ft lbs) 9,5 m.kg (68 ft lbs) 18 à 22 m.kg (130 to 160 ft lbs)

<p>1</p> <p>MANUEL DE REPARATIONS REPARATURHANDBUCH REPAIR MANUAL MANUAL DE REPARACIONES MANUALE DI RIPARAZIONE</p>		<p>OPERATIONS ARBEITSVORGÄNGE OPERATIONS OPERACIONES OPERAZIONI</p>		<p>AMI 8</p>		<p>BERLINE (AM série JA) BREAK (AM série JB) BREAK COMMERCIAL (AM série JB) BREAK SERVICE (AM série JC) 9 - 1969 →</p>	
<p>N° 559/3</p>		<p>AM3. 440 - 00 AM3. 441 - 1 AM3. 442 - 3 AM3. 443 - 1</p>					
<p>DIRECTION</p> <p>TYPE :</p> <p>A crémaillère</p> <p>Angle de braquage</p> <p>Rayon de braquage</p> <p>Rapport de démultiplication</p> <p>REGLAGES</p> <p>Parallélisme :</p> <p>(Ouverture)</p> <p>Carrossage :</p> <p>Roues en ligne droite</p> <p>Roues braquées</p> <p>TOLERANCE AU BRAQUAGE :</p> <p>- entre pneu et bras (côté braquage)</p> <p>Entre batteur et bras (côté opposé)</p> <p>NOTE : Un tour de manchon de réglage fait varier la position de la roue de :</p>	<p>LENKUNG</p> <p>TYP</p> <p>Zahnstange</p> <p>Winkel des Radeinschlages</p> <p>Radeinschlagradius</p> <p>Übersetzungsverhältnis</p> <p>EINSTELLUNGEN</p> <p>Spur :</p> <p>(Öffnet nach vorn)</p> <p>Sturz : Räder in Geradeausfahrt</p> <p>Räder eingeschlagen</p> <p>RÄDER ÖFFNEN NACH VORN :</p> <p>- Zwischen Reifen und Schwingarm (auf der Einschlagseite)</p> <p>Zwisch. Trägheitsdämpfer u. Schwingarm (andere Seite)</p> <p>ANMERKUNG : Durch eine Umdrehung der Einstellhülse verändert sich die Spur um :</p>	<p>STEERING</p> <p>TYPE :</p> <p>Rack and pinion</p> <p>Lock angle</p> <p>Turning radius</p> <p>Steering ratio</p> <p>ADJUSTMENTS</p> <p>Parallelism :</p> <p>(Toe-out)</p> <p>Camber :</p> <p>Wheels in straight ahead position</p> <p>Wheels on full lock</p> <p>CLEARANCES AT FULL LOCK :</p> <p>- between tyre and arm (inner side of turn)</p> <p>- between inertia damper and arm (outer side of turn)</p> <p>NOTE : One turn of the adjusting sleeve varies the wheel position by :</p>	<p>DIRECCION</p> <p>TIPO :</p> <p>De Cremallera</p> <p>Angulo de giro</p> <p>Radio de giro</p> <p>Relación de desmultiplicación</p> <p>REGLAJES</p> <p>Paralelismo :</p> <p>(Apertura)</p> <p>Inclinación de la rueda :</p> <p>Ruedas en línea recta</p> <p>Ruedas giradas</p> <p>TOLERANCIA AL GIRO :</p> <p>- entre neumático y brazo (lado girado)</p> <p>- entre batidor y brazo (lado opuesto)</p> <p>OBSERVACION : Una vuelta del manguito de reglaje hace variar la posición de la rueda de :</p>	<p>STERZO</p> <p>TIPO :</p> <p>A cremagliera</p> <p>Angolo di sterzata</p> <p>Raggio di sterzata</p> <p>Rapporto di demoltiplicazione</p> <p>REGOLAZIONI</p> <p>Parallelismo :</p> <p>(Apertura)</p> <p>Inclinazione ruote :</p> <p>Ruote in posizione di marcia rettilinea</p> <p>Ruote sterzate</p> <p>TOLLERANZA ANGOLO DI STERZATA :</p> <p>- fra pneumatico e braccio (lato sterzata)</p> <p>- fra battente e braccio (lato opposto)</p> <p>NOTA : Un giro di manico di regolazione fa variare la posizione della ruota da :</p>	<p>$35^{\circ} - \overset{0}{1}$</p> <p>$\frac{5,700 \text{ m}}{18 \text{ ft } 8 \frac{1}{2} \text{ in}}$</p> <p>$\frac{1}{13}$</p> <p>$1 \text{ à } 3 \text{ mm } (\frac{3}{64} \text{ to } \frac{1}{8} \text{ in})$</p> <p>$1^{\circ} \pm \frac{45'}{25'}$</p> <p>$9^{\circ}30' \pm 1^{\circ}20'$</p> <p>5 mm (3/16 in)</p> <p>1 mm (3/64 in.)</p> <p>6 à 7 mm ($\frac{15}{64}$ to $\frac{9}{32}$ in.)</p>		

2

MANUEL DE REPARATIONS
REPARATURHANDBUCH
REPAIR MANUAL
MANUAL DE REPARACIONES
MANUALE DI RIPARAZIONE

N° 559/3

OPERATIONS
ARBEITSVORGÄNGE
OPERATIONS
OPERACIONES
OPERAZIONI

AMB. 440 - 00
AMB. 441 - 1
AMB. 442 - 3
AMB. 443 - 1

AMI 8

BERLINE (AM serie JA)
BREAK (AM serie JB)
BREAK COMMERCIAL (AM serie JB)
BREAK SERVICE (AM serie JC)

9 - 1969



DIRECTION
(suite)

REGLAGE DES ROTULES

Bloquer l'écrou de butée
de rotule de crémaillère
et desserrer de :

COUPLES DE SERRAGE

Vis du collier de serrage
du tube de direction sur
pignon de crémaillère.

Ecrou de blocage du
pignon de crémaillère
Ecrou «Nylstop» des
barres sur rotules de
direction.

LENKUNG
(Forts.)

EINSTELLUNG DER
KUGELBOLZEN

Mutter der Kugelbolzen
der Zahnstange festzie-
hen und wieder lösen :

ANZUGSMOMENTE

Schraube der Schelle
zur Befestigung der
Lenksäule auf Zahn-
stangenritzel

Mutter des Zahnstangen-
ritzels
«Nylstop» Muttern der
Spurstangen

STEERING
(continued)

ADJUSTING THE
SWIVELS

Lock the nuts of the rack
ball-pins, then uncrew
by :

TIGHTENING TORQUES

Screw on the locking
collar of steering tube on
rack pinion

Locking nut on rack
pinion
«Nylstop» nuts on
trackrod ball pins

DIRECCION
(continuación)

REGLAJE DE LAS
ROTULAS

Bloquear la tuerca de
tope de rótula de cre-
mallera y aflojar de :

PARES DE APRIETE

Tornillo del collarín
de sujeción del tubo
de dirección sobre piñón
de cremallera.

Tuerca de bloqueo del
piñón de cremallera
Tuerca «Nylstop» de las
barras sobre rótulas
de dirección.

STERZO
(seguito)

REGOLAZIONE DELLE
ROTULE

Bloccare il dado di
arresto rotula della
cremagliera e allentarlo
di :

COPPIE DI SERRAGGIO

- Vite del collare di
serraggio piantone
sterzo sul pignone della
cremagliera
- Dado di bloccaggio
pignone della cremagliera
- Dadi «Nylstop» delle
barre sulle rotule della
cremagliera.

1/6

de tour
Umdrehung
of a turn
de vuelta
di giro

1,9 mkg
(1,4 ft.lbs.)

10 à 14 m.kg
(72 to 101 ft lbs)
4 m.kg
(25 ft lbs)

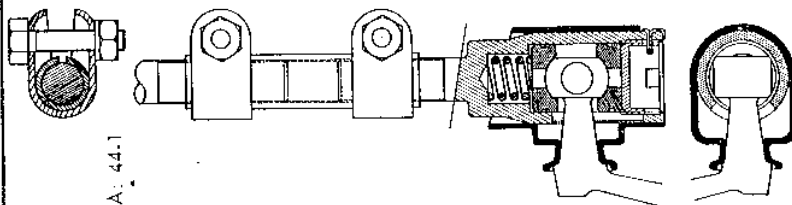

A. 44-1

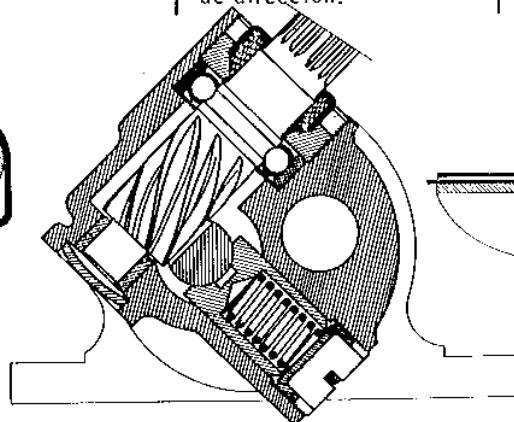

A. 44-5

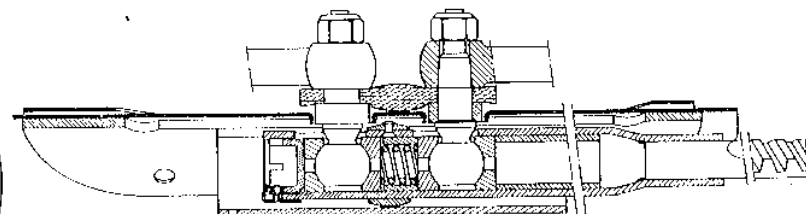

A. 44-3

<p>1</p> <p>MANUEL DE REPARATIONS REPARATURHANDBUCH REPAIR MANUAL MANUAL DE REPARACIONES MANUALE DI RIPARAZIONE</p>	<p>OPERATIONS ARBEITSVORGÄNGE OPERATIONS OPERACIONES OPERAZIONI</p>	<p>BERLINE (AM série JA) BREAK (AM série JB) BREAK COMMERCIAL (AM série JB) BREAK SERVICE (AM série JC)</p> <p>AMI 8</p> <p>N° 559/3</p> <p>AM3. 450.00^a</p> <p>9 - 1969</p>		
<p>FREINS</p>	<p>BREMSEN</p>	<p>BRAKES</p>	<p>FRENOS</p>	<p>FRENI</p>
<p>REMARQUE IMPORTANTE</p> <p>Le liquide spécial «LHM» de couleur verte, utilisé dans le circuit de freinage de ce véhicule est un liquide d'origine minérale, de même nature que l'huile de graissage du moteur.</p> <p>L'utilisation de tout autre liquide entraînerait la détérioration complète des caoutchoucs et des joints d'étanchéité.</p> <p>Les organes appropriés sont peints ou repérés en vert et ne doivent être remplacés que par des organes d'origine également peints ou repérés en vert. Ils ne doivent être utilisés que sur les véhicules équipés de freins à disque.</p> <p>Le nettoyage peut être effectué à l'essence ou à l'essence «C». Le séchage à l'air comprimé. Ne pas utiliser d'alcool.</p>	<p>WICHTIGE ANMERKUNG</p> <p>Die im Bremskreislauf dieses Fahrzeuges verwendete Spezialflüssigkeit «LHM» von grüner Farbe ist eine Flüssigkeit mineralischer Herkunft von derselben Art wie das Motorenöl.</p> <p>Die Verwendung einer jeden anderen Flüssigkeit würde die vollständige Zerstörung der Gummitteile und Dichtungen zur Folge haben.</p> <p>Die entsprechenden Organe sind grün gestrichen oder grün markiert und können nur durch ebenfalls grün gestrichene oder markierte Teile ausgewechselt werden. Sie dürfen nur bei Fahrzeugen mit Scheibenbremsen Verwendung finden.</p> <p>Die Reinigung kann mit Normal- oder C. Benzin erfolgen und das Abtrocknen mit Pressluft. Keinen Alkohol verwenden.</p>	<p>IMPORTANT NOTE</p> <p>The special «LHM» Fluid, green in colour used in the braking circuit of this vehicle is a mineral liquid, of the same type as engine oil.</p> <p>The use of any other liquid would cause rapid and complete deterioration of the rubber items and seals in the system.</p> <p>The appropriate units are painted or marked in green, and must not be replaced otherwise than with original units also painted or marked in green. They must only be used on vehicle fitted with disc-brakes.</p> <p>Cleaning can be carried out with petrol or white spirit. Dry with compressed air.</p> <p>Do not use alcohol.</p>	<p>OBSERVACION IMPORTANTE</p> <p>El líquido especial «LHM» de color verde, utilizado en el circuito de freno de este vehículo es un líquido de origen mineral de la misma naturaleza que el aceite de engrase del motor.</p> <p>La utilización de cualquier otro líquido ocasionaría la deterioración total de gomas y juntas de estanqueidad.</p> <p>Los órganos apropiados están pintados o marcados de verde y no deben ser reemplazados que por órganos de origen igualmente pintados o señalados de verde. No deben ser utilizados que sobre los vehículos equipados con frenos de disco.</p> <p>La limpieza se puede efectuar con gasolina o con esencia «C» el secado con aire comprimido.</p> <p>No utilizar alcohol.</p>	<p>OSSERVAZIONE IMPORTANTE</p> <p>Il liquido speciale «LHM» di colore verde impiegato nel circuito di frenatura di questo veicolo è un liquido di origine minerale della stesso tipo dell'olio motore.</p> <p>L'impiego di qualsiasi altro tipo di liquido provocherebbe il deterioramento completo delle guarnizioni e dei gommini di tenuta.</p> <p>Gli organi appropriati sono verniciati o contrassegnati in verde dovranno essere sostituiti solo con organi originali anch'essi verniciati o contrassegnati in verde. Essi dovranno essere impiegati solo sui veicoli muniti di freni a disco.</p> <p>La pulizia può essere effettuata con benzina o benzina «C». Ausciugare con aria compressa.</p> <p>Non impiegare alcool.</p>

MANUEL DE REPARATIONS
REPARATURHANDBUCH
REPAIR MANUAL
MANUAL DE REPARACIONES
MANUALE DI RIPARAZIONE

N° 559-3

OPERATIONS
ARBEITSVORGÄNGE
OPERATIONS
OPERACIONES
OPERAZIONI

AM3-450-00 a

AMI 8

BERLINE (AM série JA)
BREAK (AM série JB)
BREAK COMMERCIAL (AM série JB)
BREAK SERVICE (AM série JC)

9-1969



FREINS
(suite)

BREMSEN
(Forts.)

BRAKES
(continued)

FRENOS
(continuación)

FRENI
(seguito)

MAITRE CYLINDRE - HAUPTBREMSZYLINDER - MASTER CYLINDER - BOMBA DE FRENOS - CILINDRO MAESTRO

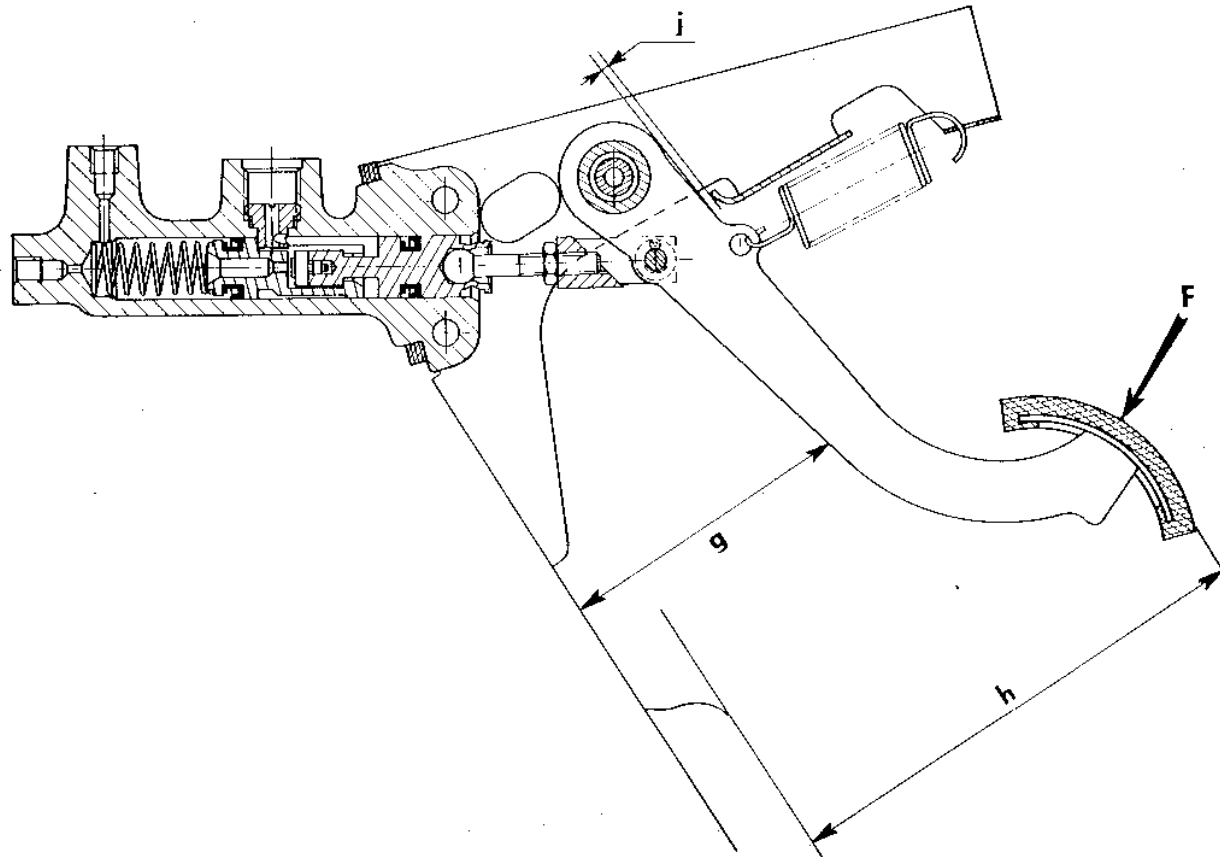

A. 45-58

FREINS (suite)	BREMSEN (Forts.)	BRAKES (continued)	FRENOS (continuación)	FRENI (seguito)	
COTES Garantie entre pédale et support J pour H Garantie entre pédale et plancher sous : F = 300 kg, g =	MASSE Spiel zwischen Pedal und Träger J bei H Spiel zwischen Pedal und Wagen boden unter : F = 300 kg, g =	DIMENSIONS Clearance between pedal and bracket J = at H = Gap between pedal and floor under : load of 660 lbs, g =	COTAS Garantía entre pedal y soporte J = en H Garantía entre pedal y piso bajo : F = 300 kg, g =	QUOTE Gioco tra pedale e supporto J = per H Gioco tra pedale e pavimento sotto : F = 300 kg, g =	2 mm mini 120 ± 2,5 mm 50 mm mini
MAITRE-CYLINDRE Sans soupape de pression résiduelle Diamètre de l'alésage Longueur de la tige de poussée. Jeu à l'attaque entre piston et piston. Retrait de la garniture des raccords à l'extrémité du tube.	HAUPTBREMSZYLINDER ohne Bodenventil Bohrungs - ϕ Länge des Stössels : Anschlagsspiel zwischen Stössel und Kolben. Rückstand der Dichtungsgarnitur am Ende des Rohres.	MASTER-CYLINDER Without residual pressure valve Bore dia Length of push-rod Clearance between push-rod and piston. Inset of sleeve-seal from end of tube.	BOMBA DE FRENOS Sin válvula de presión residual Diámetro del cilindro Longitud de la varilla de empuje. Juego de ataque entre empujador y pistón. Retracción de la garnición de los racores a la extremidad del tubo.	CILINDRO-MAESTRO Senza valvola della pressione residua Diametro dell'alesaggio Lunghezza asta di spinta. Gioco d'attacco fra asta di spinta e pistone. Rientranza della guarnizione dei raccordi all'estremità del tubo.	17,5 mm (11/16 in) 81,5 ± 0,25 mm (3.2 in ± 0,010 in) 0,5 mm maxi (0.020 in) 2 mm (5/64 in)
CONTACTEUR DE STOP Allumage pour une courbe maxi de :	BREMSLICHTSCHALTER Aufleuchten bei einem Weg von maximal :	STOPLAMP SWITCH Lamp Lights at pedal movement of :	CONTACTOR DE PARE Debe encender con un recorrido maximo de :	CONTATTORE DELLO STOP Accensione per una corsa massima di :	10 mm (3/8 in)
COUPLES DE SERRAGE Ecrou de roulement avant d'arbre de différentiel Raccord des tubes d'alimentation de freins.	ANZUGSMOMENTE Mutter des Differentialwellenlagers Anschluss der Bremsleitung.	TIGHTENING TORQUES Nut on front bearing of differential shaft Screwed unions on brake feed pipes.	PARES DE APRIETE Tuerca del rodamiento delantero del árbol de diferencial Racores de tubos de alimentación de frenos.	COPPIE DI SERRAGGIO Dado del cuscinetto ant. del semiass Raccordi dei tubi di alimentazione dei freni.	10 à 12 m.kg (72 to 217 ft. lbs) 0,6 à 0,8 mkg (4,3 to 5,8 ft. lbs)

MANUEL DE REPARATIONS
REPARATURHANDBUCH
REPAIR MANUAL
MANUAL DE REPARACIONES
MANUALE DI RIPARAZIONE

N° 559/3

OPERATIONS
ARBEITSVORGÄNGE
OPERATIONS
OPERACIONES
OPERAZIONI

AM3. 450-00 a
AM3. 451- 1 a
AM3. 453- 6
AM3. 454- 0 a

AMI 8

BERLINE (AM Série JA)
BREAK (AM Série JB)
BREAK COMMERCIAL (AM Série JB)
BREAK SERVICE (AM Série JC)
9 - 1969

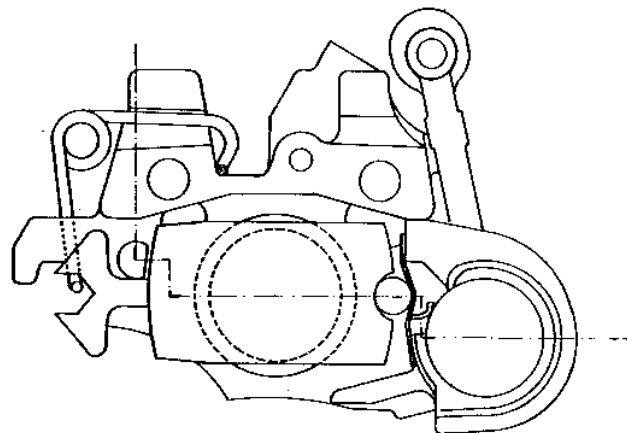

ETRIERS DE FREINS AVANT
VORDERE BREMSTRAGPLATTEN
FRONT BRAKE UNITS
ESTRIBOS DE FRENOS DELANTEROS
STAFFE FRENO ANTERIORI

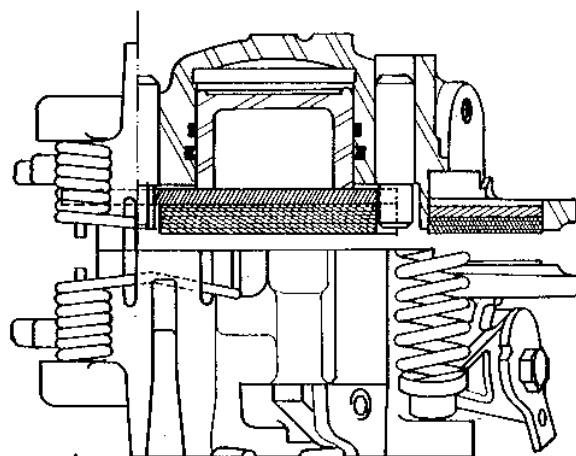

FREINS DE SECURITE
HANDBREMSE
PARKING-BRAKE
FRENO DE EMERGENCIA
FRENO DI SOCCORSO

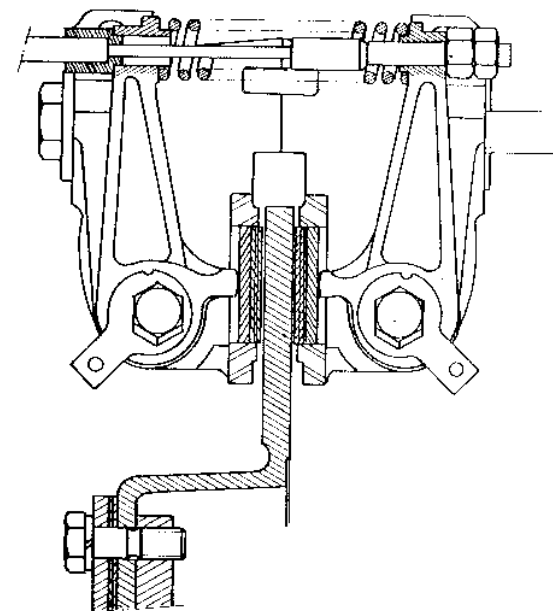
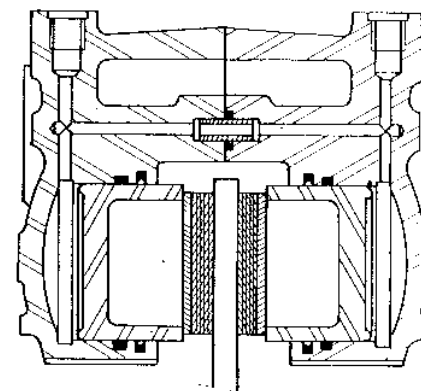

5 ETRIER DE FREINS AVANT	VORDERE BREMSTRAGPLATTE	FRONT BRAKE UNIT	ESTRIBO DE FRENOS DELANTEROS	STAFFE FRENO ANTERIORI	
PISTON DE L'ETRIER	KOLBEN DER TRAGPLATTE	PISTON	PISTON DE ESTRIBO	PISTONE DELLA STAFFA	
Diamètre extérieur :	Aussen- ϕ =	O.D.	Diametro exterior	Diametro esterno	42 mm
DISQUE DE FREIN	BREMSSCHEIBE	BRAKE DISC	DISCO DE FRENO	DISCO FRENO	244 mm
Diamètre :	ϕ	Diameter =	Diametro =	Diametro =	7 mm
Epaisseur d'origine	Originalstärke	Original thickness	Espesor de origen	Spessore originale	4 mm
Epaisseur minimum	Mindeststärke	Minimum thickness	Espesor mínimo	Spessore minimo	0,2 mm
Voile maximum	Höchstzulässiger Schlag	Maximum run-out	Alaveo máximo	Svergolamento massimo	
ETRIER	TRAGPLATTE	BRAKE-UNIT	ESTRIBO	STAFFA	
Position de l'étrier par rapport au disque : plan de joint des deux demi-étriers dans le plan médian de face du disque à :	Stellung der Tragplatte zur Bremscheibe : die Achse der Dichtungsauflagefläche der beiden Tragplattenhälften muss mit der Mitte der Bremscheibe übereinstimmen :	Position of unit in relation to disc : joint face of two half units in line with median plane of disc, to within :	Posición del estribo con relación al disco : plano de union de los dos semi estribos en el plano central del espesor del disco, a :	Posizione della staffa rispetto al disco : piano di giunzione delle due semistaffe nel piano medio della faccia del disco a :	0 ± 0,5 mm
PLAQUETTES	PLAKETTEN	BRAKE SHOES	PLAQUETAS	PLACCHETTE	22 cm ² (3.41 sq. in)
Surface d'une plaquette de frein principal.	Fläche einer Plakette für die Betriebsbremse.	Area of friction face of one main lining.	Superficie de una plaqueta de freno principal.	Superficie di una placchetta freno principale.	
Surface d'une plaquette de frein de sécurité.	Fläche einer Plakette für die Feststellbremse.	Area of friction face of one parking brake lining.	Superficie de una plaqueta de freno de emergencia.	Superficie di una pastiglia freno di soccorso.	7 cm ² (1.09 sq. in)
Garantie entre plaquettes de frein de sécurité et disque :	Spiel zwischen Plaketten der Feststellbremse und Bremscheibe :	Clearance between parking brake lining and discs :	Garantía entre plaquetas de freno de emergencia y disco :	Gioco fra pastiglia freno di soccorso e disco :	
0,1 mm au voile maxi du disque.	0,1 mm am grössten Schlag der Scheibe.	0,1 mm at point of max. disc run-out.	0,1 mm de alaveo máximo del disco.	0,1 mm al punto di svergolamento massimo del disco.	
COUPLES DE SERRAGE	ANZUGSMOMENTE	TIGHTENING TORQUES	PARES DE APRIETE	COPPIE DI SERRAGGIO	4,5 à 5 mkg (33 to 36 ft. lbs)
Vis de fixation des étriers.	Befestigungsschrauben der Tragplatte.	Screws securing brake units	Tornillos fijación de los estribos.	Viti di fissaggio delle staffe	4 mkg (29 ft lbs)
Vis de fixation des excentriques.	Befestigungsschrauben der Bremsexcenter-	Screws securing eccen-	Tornillos fijación de las excentricas.	Viti di Fissaggio degli eccentrici.	
Vis de fixation du disque	Schrauben z. Befest. d.	Screws fixing disc	Tornillos de fijación del disco	Viti di Fissaggio disco	4,5 à 5 mkg (33 to 36 ft. lbs)
Ecrou raccord hydraulique	Scheibe. Mutter f. hydr. An-	Union screw for piping	Tuerca racord hidráulico	Dado raccordo idraulico	0,8 à 0,9 mkg (5,8 to 6,5 ft. lbs)
Contre-écrou de câble de frein de sécurité.	schluss. Kontermutter f. Zug der Feststellbremse.	Lock nut for parking brake cable.	Contratuerca del cable del freno de emergencia.	Controdado del cavo freno di soccorso.	1,5 mkg (11 ft. lbs)

6	MANUEL DE REPARATIONS REPARATURHANDBUCH REPAIR MANUAL MANUAL DE REPARACIONES MANUALE DI RIPARAZIONE	N° 559-3	OPERATIONS ARBEITSVORGÄNGE OPERATIONSI OPERACIONES OPERAZIONI	AM 3-241-1 NT 116-A AM 3-454-4	AMI 8 BERLINE (AM série JA) BREAK (AM série JB) BREAK COMMERCIAL (AM série JB) BREAK SERVICE (AM série JC) 9 - 1969 
FREINS (suite)	BREMSEN (Forts.)	BRAKES (continued)	FRENOS (continuación)	FRENI (seguito)	
<p>Garnitures des plaquettes de frein principal</p> <p>Garnitures des pastilles du frein de sécurité</p> <p>GOULOTTES DE REFROIDISSEMENT</p> <p>Depuis le 13 - 10 - 1969 le refroidissement des disques de freins avant est assuré par deux prises d'air sur le collecteur d'air du moteur</p> <p>Les goulottes gauche et droite sont fixées sur le carter de boîte de vitesses par deux pattes en tôle, fixées, à l'avant par les goujons inférieurs d'assemblage moteur-boîte à l'arrière par les vis de fixation du pot de détente</p>	<p>Beläge der Plaketten der Betriebsbremse</p> <p>Beläge der Plättchen der Feststellbremse</p> <p>KÜHLSTUTZEN</p> <p>Ab. 13 - 10 - 1969 erfolgt die Kühlung der Brems Scheiben der Vorderradbrem sen durch zwei Luftanschlüsse an der Luftführung des Motors</p> <p>Der linke und rechte Stutzen ist durch zwei Blechlaschen am Getriebegehäuse befestigt, die ihrerseits vorne durch die unteren Stehbolzen zum Anflanschen von Motor und Getriebegehäuse und hinten durch die Schrauben zur Befestigung des Auspufftopfes gehalten werden</p>	<p>Linings of front brake shoes, main</p> <p>Linings of parking brake</p> <p>COOLING DUCT</p> <p>Since 13-10-1969, cooling of the brake discs, front is ensured by two air in takes on the fan cowl of the engine</p> <p>The LH and RH air ducts are fixed on the gearcase by two metal clips, secured at the front by the lower studs assembling the engine to the gearbox, at the rear by the screws fixing the expansion chamber</p>	<p>Guarnecidos de las plaquetas del freno principal</p> <p>Guarnecidos de las pastillas del freno de emergencia</p> <p>CONDUCTOS DE REFRIGERACION</p> <p>A partir del 13-10-1969 la refrigeración de los discos de frenos delanteros está asegurada por dos tomas de aire derivadas del colector de aire del motor</p> <p>Los conductos derecho e izquierdo están fijados sobre el cárter de la caja de velocidades por dos patillas de chapa, fijadas adelante por los espárragos inferiores de ensamblado motor caja y atrás por los tornillos de fijación del silenciador</p>	<p>Guarniture placchette freno principale</p> <p>Guarniture pastiglie freno di soccorso</p> <p>CONDOTTI DI RAFFREDDAMENTO</p> <p>Dal 13-10-1969 il raffreddamento dei dischi freno anteriori é assicurato da due prese d'aria sul collettore dell'aria del motore</p> <p>I condotti sinistro e destro sono fissati sul carter scatola cambio da due staffe in lamiera fissate anteriormente tramite i prigionieri inferiori di assemblaggio motore scatola cambio e posteriormente dalle viti di fissaggio della marmitta di scarico</p>	<p>FERODO 554</p> <p>FERODO 738</p>

REFROIDISSEMENT - KÜHLSYSTEM - COOLING - REFRIGERACION - RAFFREDDAMENTO

7184

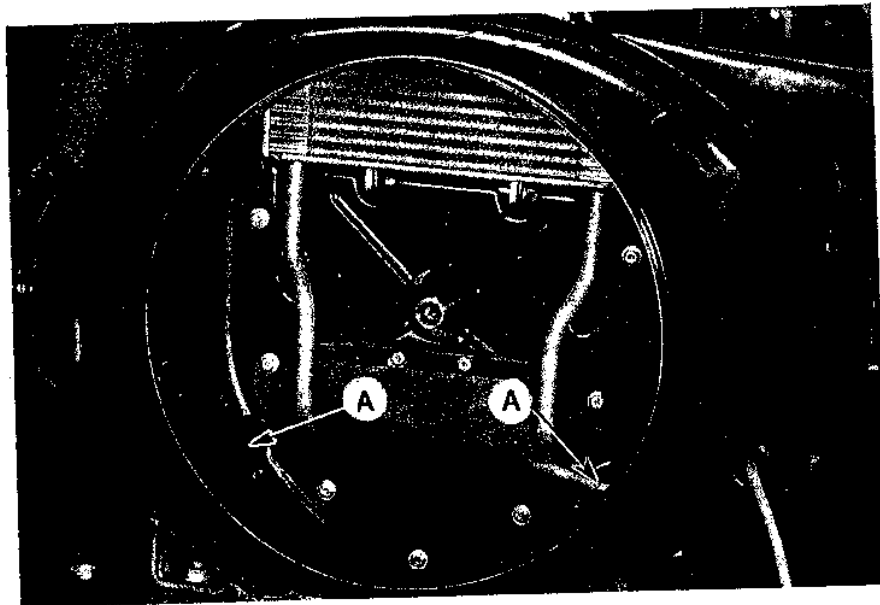

PRISES D'AIR DE REFROIDISSEMENT (A)
 LUFTANSCHLÜSSE FÜR KÜHLLUFT
 COOLING - AIR INLETS
 COLECTOR DE AIRE DE LA REFRIGERACION
 PRESE ARIA DI RAFFREDDAMENTO

7178



POSITION D'UNE GOULOTTE DE REFROIDISSEMENT
 STELLUNG EINES KÜHLLUFTSTUTZENS
 POSITION OF COOLING DUCT
 POSICION DE UN CONDUCTO DE REFRIGERACION
 POSIZIONE DI UN CONDOTTO DI RAFFREDDAMENTO

MANUEL DE REPARATIONS
REPARATURHANDBUCH
REPAIR MANUAL
MANUAL DE REPARACIONES
MANUALE DI RIPARAZIONE

N° 538/1

OPERATIONS
ARBEITSVORGÄNGE
OPERATIONS
OPERACIONES
OPERAZIONI

AM3-450-00 a
AM3-451-4
AM3-453-6
NT. 121-A

AMI 8

BERLINE (AM Série JA)
BREAK (AM Série JB)
BREAK COMMERCIAL (AM Série JB)
BREAK SERVICE (AM Série JC)

9 - 1969



FREINS
(suite)

BREMSEN
(Forts.)

BRAKES
(continued)

FRENOS
(continuación)

FRENI
(seguito)

Notes : Depuis le 6.4.1970 les plaquettes de frein principal de ces véhicules sont garnies de FERODO-736.

ANM : Ab 6.4.1970 sind die Plaketten der Betriebsbremse dieser Fahrzeuge mit FERODO-736

Note : Since 6.4. 1970 the main brake pads of these vehicles are in FERODO-736.

Observación : A partir del 6.4.1970 las plaquetas del freno principal de estos vehículos están guarnecidas con FERODO-736.

Note : Dal 6.4.1970 le placchette freno principale di questi veicoli sono munite di guarniture FERODO 736.

En cas de remplacement de plaquettes de freins il faut obligatoirement que les quatre garnitures soient de même qualité.

Belägen ausgetauscht
Bei Auswechseln der Bremsplaketten müssen die vier Beläge von der gleichen Qualität sein.

In case of replacement of brake linings it is essential that all four linings be of the same quality.

En caso de sustitución de las plaquetas de freno es imperativo que los cuatro guarnecidos sean de la misma calidad.

In caso di sostituzione delle placchette freno è indispensabile che le quattro guarniture siano della stessa qualità.

Depuis le 15.11.1969 les ressorts anti-bruit des pastilles de frein de sécurité sont modifiés.

Ab 15.11.1969 sind die Geräuschdämpfungsfedern für die Feststellbremse geändert.

Since 15.11.1969, the anti-noise springs of the parking brake linings are modified.

A partir del 15.11.1969 las muelles antiruido de las pastillas del freno de emergencia han sido modificados.

Dal 15.11.69 le molle antirumore delle pastiglie freno di soccorso sono modificate.

Sur chaque ressort, deux angles extrêmes pliés à 90° (voir figure) s'incrument légèrement dans l'aluminium de l'étrier.

An jeder Feder sitzen zwei äussere auf 90° gebogene Winkel (siehe Abb.) leicht im Aluminium der Tragplatte.

On each spring, two corners are bent in at 90° (see sketch) and bite lightly into the aluminium of the brake unit

Sobre cada muelle dos dobles a 90° (ver figura) en los extremos, se incrustan en el aluminio del estribo.

Su ogni molla due angoli estremi piegati a 90° (ved Figura) s'incastano leggermente nell'alluminio della staffa.

FREINS
(suite)BREMSEN
(Forts.)BRAKES
(continued)FRENOS
(continuación)FRENI
(seguito)

Ressort anti-bruit de pastilles de frein de sécurité
 Geräuschdämpfungsfeder für Plättchen der Feststellbremse
 Anti-noise spring for parking-brake pads
 Muelle antirruído de pastillas del freno de emergencia
 Molla antirumore delle pastiglie del freno di soccorso

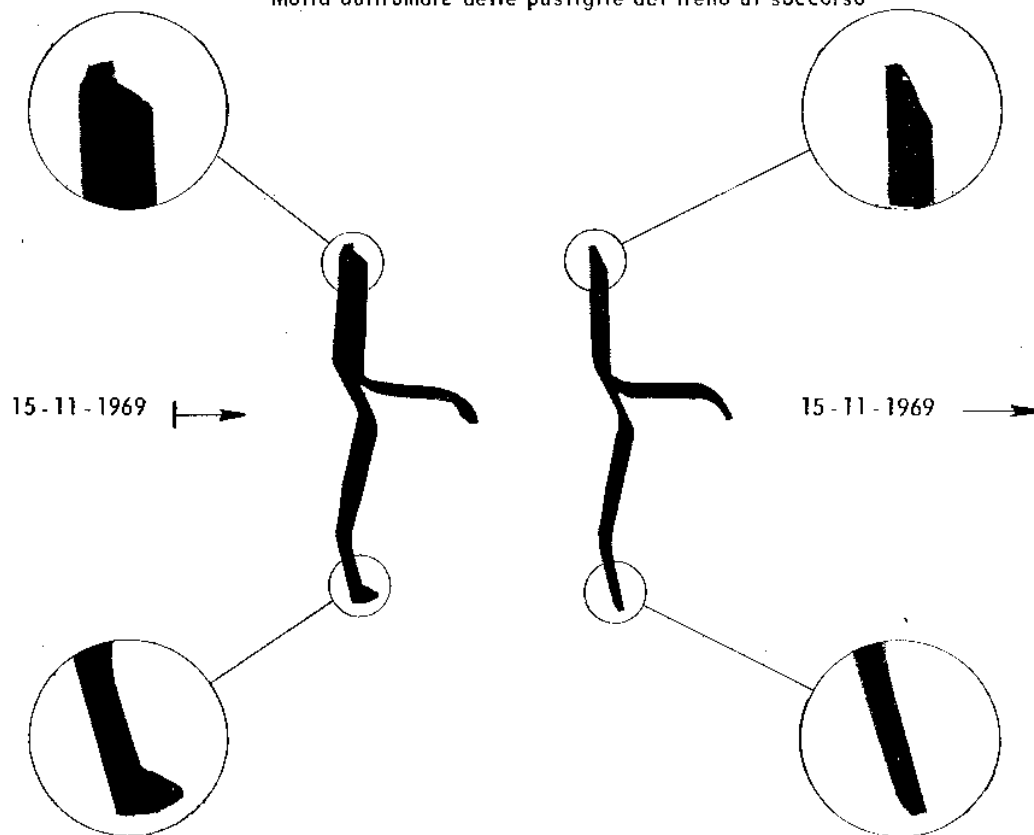

MANUEL DE REPARATIONS
 REPARATURHANDBUCH
 REPAIR MANUAL
 MANUAL DE REPARACIONES
 MANUALE DI RIPARAZIONE

N° 559-3

OPERATIONS
 ARBEITSVORGÄNGE
 OPERATIONS
 OPERACIONES
 OPERAZIONI

AM3 . 450-00a
 AM3 . 451-4

AMI 8

BERLINE (AM série JA)
 BREAK (AM série JB)
 BREAK COMMERCIAL (AM série JB)
 BREAK SERVICE (AM série JC)

9-1969



FREINS ARRIERE - HINTERRADBREMSEN - REAR BRAKES - FRENOS TRASEROS - FRENI POSTERIORI

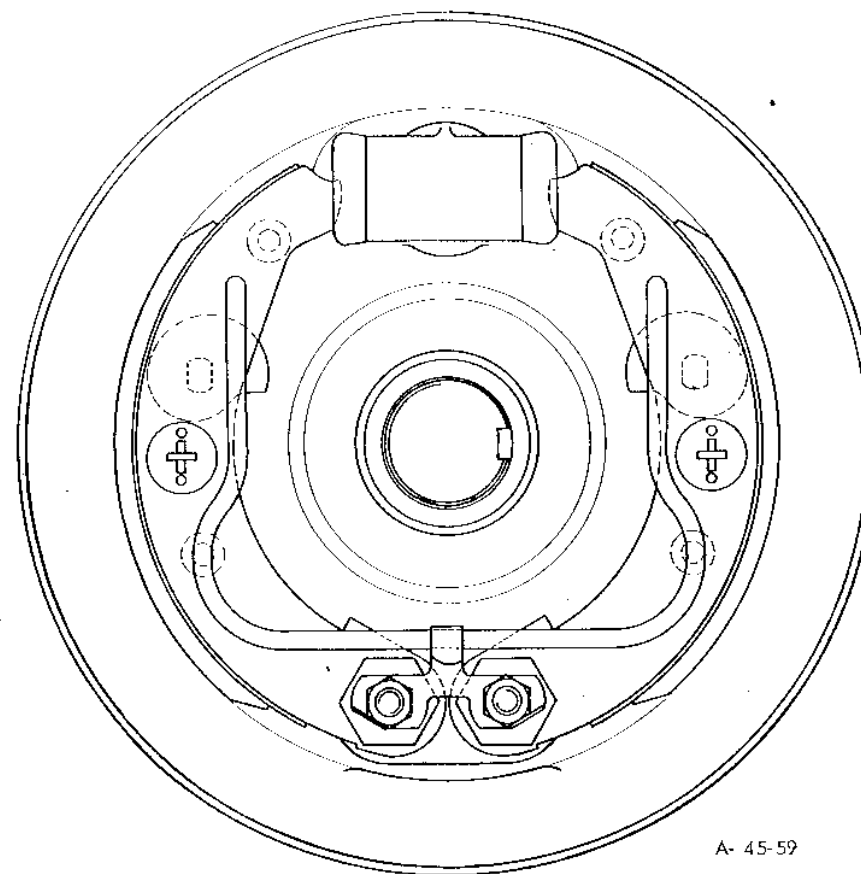
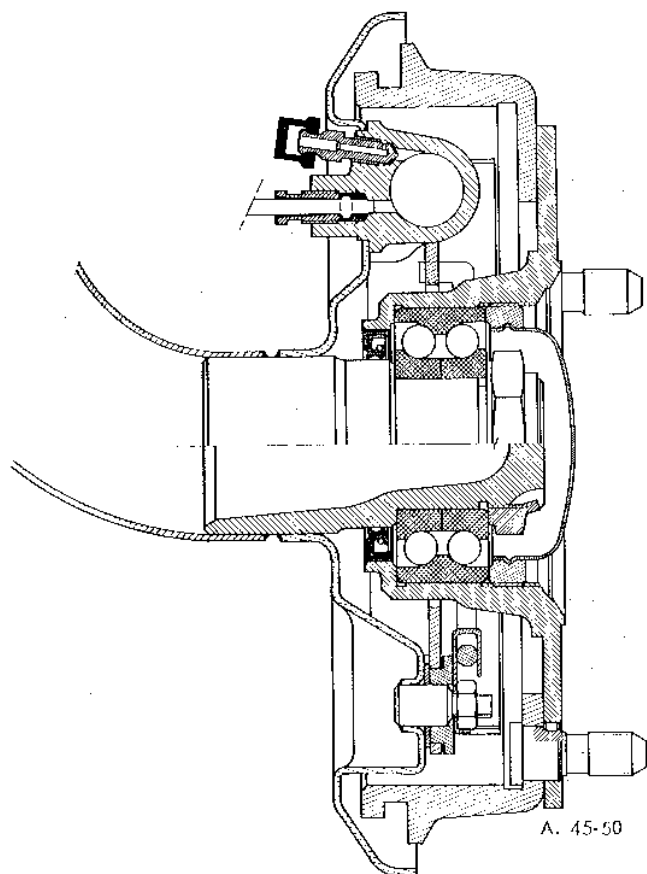

II	MANUEL DE REPARATIONS REPARATURHANDBUCH REPAIR MANUAL MANUAL DE REPARACIONES MANUALE DI RIPARAZIONE	OPERATIONS ARBEITSVORGÄNGE OPERATIONS OPERACIONES OPERAZIONI	AMI 8 BERLINE (AM série JA) BREAK (AM série JB) BREAK COMMERCIAL (AM série JB) BREAK SERVICE (AM série JC) 9-1969 
		AM3 450-00 a AM3 451-4	
		N° 559/3	

FREINS ARRIERE	HINTERE BREMSEN	REAR BRAKES	FRENO TRASERO	FRENI POSTERIORI		
DIAMETRE D'ORIGINE DES TAMBOURS :	TROMMELDURCHMESSER:	ORIGINAL DIAMETER OF DRUMS :	DIAMETRO DE ORIGEN DE LOS TAMBORES :	DIAMETRO ORIGINALE DEI TAMBURI :		
<ul style="list-style-type: none"> - Rectification maxi sur le diamètre 	<ul style="list-style-type: none"> - Ausdrehen der Trommel maxi 	<ul style="list-style-type: none"> - Maximum grinding (on diameter) 	<ul style="list-style-type: none"> - Rectificación máxi- (sobre el diámetro) 	<ul style="list-style-type: none"> - Rettifica massima (sul diametro) 	180 mm (7.09 in)	
<ul style="list-style-type: none"> - Faux rond maxi 	<ul style="list-style-type: none"> - Schlag der Trommel maxi 	<ul style="list-style-type: none"> - Maximum eccentricity 	<ul style="list-style-type: none"> - Falso redondo máxi- 	<ul style="list-style-type: none"> - Falsa concentricità mass. 	2 mm (0,08 in)	
TYPE DE GARNITURE	BREMSBELÄGE	TYPE OF LINING	TIPO DE GUARNECIDOS	TIPO DI GUARNITURE		
<ul style="list-style-type: none"> - Epaisseur d'origine - Largeur 	<ul style="list-style-type: none"> - Originalstärke - Breite 	<ul style="list-style-type: none"> - Thickness when new - Width 	<ul style="list-style-type: none"> - Espesor de origen - Ancho 	<ul style="list-style-type: none"> - Spessore originale - Larghezza 	FERODO 604	4,8 à 5,9 mm (0,19 to 0,21 in)
CYLINDRES DE ROUES (avec joints toriques)	RADBREMSZYLINDER (mit Ringdichtungen)	WHEEL CYLINDERS (with ring seals)	CILINDRO DE RUEDAS (con juntas tóricas)	CILINDRETTI RUOTA (con gommini di tenuta)		
<ul style="list-style-type: none"> - Diamètre de l'alésage : 	<ul style="list-style-type: none"> - Bohrungsdurchmesser : 	<ul style="list-style-type: none"> - dia. of bore : 	<ul style="list-style-type: none"> - Diámetro del cilindro : 	<ul style="list-style-type: none"> - Diametro dell'alessaggio : 	AM3	AMF3-AMC3-AMU3
<ul style="list-style-type: none"> - Diamètre de l'alésage : 	<ul style="list-style-type: none"> - Bohrungsdurchmesser : 	<ul style="list-style-type: none"> - dia. of bore : 	<ul style="list-style-type: none"> - Diámetro del cilindro : 	<ul style="list-style-type: none"> - Diametro dell'alessaggio : 	16 mm (5/8 in)	17,5 mm (11/16 in)
COUPLES DE SERRAGE	ANZUGSMOMENTE	TIGHTENING TORQUES	PARES DE APRIETE	COPPIE DI SERRAGIO		
<ul style="list-style-type: none"> - Ecrou de blocage de roulement de moyeu 	<ul style="list-style-type: none"> - Mutter der hinteren Nabe 	<ul style="list-style-type: none"> - Nut locking rear hub bearing 	<ul style="list-style-type: none"> - Tuerca de bloqueo del rodamiento de buje trasero 	<ul style="list-style-type: none"> - Dado di bloccaggio cuscinetto del mozzo 		27 à 30 m.kg (195 to 217 ft. lbs)
<ul style="list-style-type: none"> - Bague écrou de blocage de roulement de moyeu 	<ul style="list-style-type: none"> - Ringmutter zur Blockierung des Rohnabenlagers 	<ul style="list-style-type: none"> - Shrouded nut locking hub bearing 	<ul style="list-style-type: none"> - Casquillo tuerca de bloqueo del rodamiento de buje 	<ul style="list-style-type: none"> - Ghiera di bloccaggio cuscinetto del mozzo 		35 à 40 m.kg (230 to 290 ft. lbs)
<ul style="list-style-type: none"> - Raccords des tubes d'alimentation de freins 	<ul style="list-style-type: none"> - Anschluss der Bremsleitungen 	<ul style="list-style-type: none"> - Screwed unions on brake feed pipes 	<ul style="list-style-type: none"> - Racores de tubos de alimentación de frenos 	<ul style="list-style-type: none"> - Raccordi dei tubi di alimentazione dei freni 		0,6 à 0,8 m.kg (4,3 to 5,8 ft. lbs)

1	MANUEL DE REPARATIONS REPARATURHANDBUCH REPAIR MANUAL MANUAL DE REPARACIONES MANUALE DI RIPARAZIONE	N° 559/4	OPERATIONS ARBEITSVORGÄNGE OPERATIONS OPERACIONES OPERAZIONI	AM3. 532-0 AM3. 532-3	AMI 8	BERLINE (AM série JA) BREAK (AM série JB) BREAK COMMERCIAL (AM série JB) BREAK SERVICE (AM série JC) 9 - 1969 →
---	---	----------	--	------------------------------	-------	--

ELEMENTS DE CHARGE - STROMAGGREGATE - BATTERY CHARGING - ELEMENTOS DE CARGA - ELEMENTI DI CARICA
 BATTERIE - BATTERIE - BATTERY - BATERIA - BATTERIA

CAPACITE - KAPAZITÄT - CAPACITY - CAPACIDAD - CAPACITÀ		30 AH
TYPE	}	STECO FULMEN TEM TUDOR DININ
TYP		
TYPE		
TIPO		
TIPO		
		AS 209 1663 6DH3

ALTERNATEUR - WECHSELSTROMLICHTMASCHINE - ALTERNATOR - ALTERNADOR - ALTERNATORE - 12 Volts.

MARQUE - HERSTELLER - MAKE - MARCA - MARCA	DUCELLIER	PARIS - RHONE
REFERENCE - MARKIERUNG - REFERENCE - REFERENCIA - RIFERIMENTO	7532 - A	A11 M6

Puissance nominale	Nominalleistung	Nominal out put	Potencia nominal	Potenza nominale	400 W
Intensité maxi	Max. Stromstärke	Max. current	Intensidad máxima	Intensita massima	28 A
Vitesse maxi d'utilisation	Max. Betriebsdrehzahl	Max. running speed.	Velocidad máxima de utilización	Velocita massima d'utilizzazione	12000 tr/mn
Résistance du rotor	Widerstand des Rotors	Rotor resistance	Resistencia del rotor	Resistenza del rotore	7 ± 0.2 Ω

MANUEL DE REPARATIONS
REPARATURHANDBUCH
REPAIR MANUAL
MANUAL DE REPARACIONES
MANUALE DI RIPARAZIONE

N° 559/4

OPERATIONS
ARBEITSVORGÄNGE
OPERATIONS
OPERACIONES
OPERAZIONI

AM3. 000

AM3. 535-0

AMI 8

BERLINE (AM série JA)
BREAK (AM série JB)
BREAK COMMERCIAL (AM série JB)
BREAK SERVICE (AM série JC)
9-1969



- CIRCUIT DE CHARGE
- SCHALTSCHHEMA
- CHARGING CIRCUIT
- CIRCUITO DE CARGA
- CIRCUITO DI CARICA

ALTERNATEUR
WECHSELSTROMLICHTMASCHINE
ALTERNATOR
ALTERNADOR
ALTERNATORE

REGULATEUR
REGLER
REGULATOR
REGULADOR
REGOLATORE

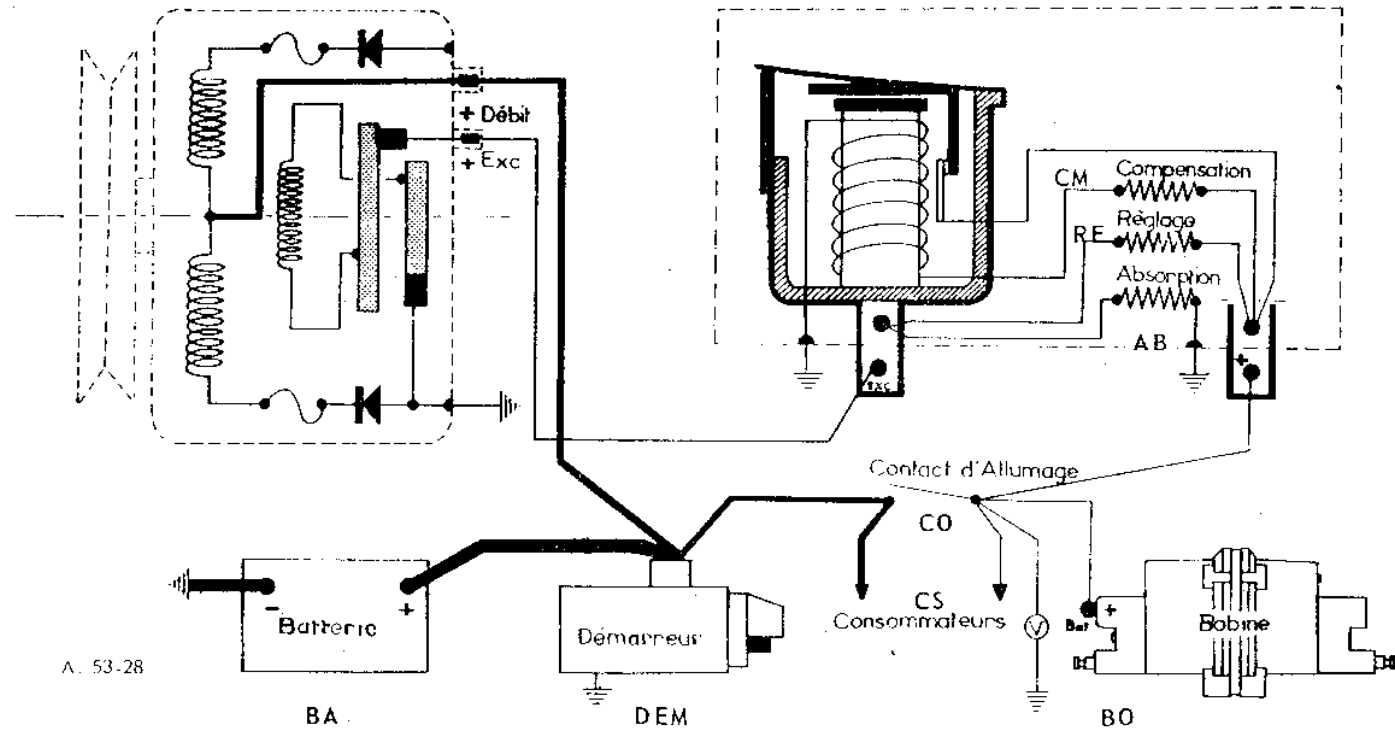

A. 53-28

BA

DEM

BO

AB	Absorption	Abschaltung	Absorption	Absorción	Assorbimento	CS	Consommateurs	Verbraucher	Circuits	Servicios	Apparecchiature
BA	Batterie	Batterie	Battery	Bateria	Batteria	DEB	Débit	Leistung	Output	Carga	Erogazione
BO	Bobine	Zündspule	Coil	Bobina	Bobina	DEM	Démarrreur	Anlasser	Starter motor	Arranque	Motorino d'avv.
CM	Compensation	Angleichen	Balancing	Compensación	Compensazione	EXC	Excitation	Errerung	Excitation	Excitación	Eccitazione
CO	Contact all.	Zündkontakt	Ignition switch	Contacto encendido	Contacto accens.	RE	Réglage	Regulierung	Regulation	Reglaje	Regolazione

3						ALTERNATEUR - WECHSELSTROMLICHTMASCHINE - ALTERNATOR - ALTERNADOR - ALTERNATORE - 12 Volts					
MARQUE - HERSTELLER - MAKE ; MARCA - MARCA					DUCELLIER		PARIS - RHONE				
REFERENCE - MARKIERUNG - REFERENCE - REFERENCIA - RIFERIMENTO					7532 - A		A 11 - M6				
Débit sous 14 V		Leistung bei 14 V		Out put at 14 V		Carga bajo 14 V		Erogazione sotto 14 V		{ 6 A à 1900 tr/mn 22 A à 4200 tr/mn 28 A à 8000 tr/mn	
REGULATEUR - REGLER - REGULATOR - REGULADOR - REGOLATORE - 12 Volts											
MARQUE - HERSTELLER - MARK ; MARCA - MARCA					DUCELLIER		PARIS - RHONE				
REFERENCE - MARKIERUNG - REFERENCE - REFERENCIA - RIFERIMENTO					8347 B		AYA - 213				
Régulation (à froid) vitesse de rotation		Regulierung (in kalt. Zust.) Drehzahl		Regulation (cold) speed of rotation		Regulación (en frío) velocidad de rota- ción		Regolazione (a freddo) velocità di rotazione		5000 tr/mn	
Elément régulateur de tension		Spannungsrege- lungselement.		Voltage regulation		Elemento regulador de tensión		Elemento regolatore di tensione		14 à 14,6V - 15A	

1	MANUEL DE REPARATIONS REPARATURHANDBUCH REPAIR MANUAL MANUAL DE REPARACIONES MANUALE DI RIPARAZIONE	N° 559/4	OPERATIONS ARBEITSVORGÄNGE OPERATIONS OPERACIONES OPERAZIONI	AM3 533-0 AM3 533-1 AM3 533-3 AM3 535-0	AMI 8	BERLINE (AM série JA) BREAK (AM série JB) BREAK COMMERCIAL (AM série JB) BREAK SERVICE (AM série JC) 9-1969 
---	--	----------	---	--	-------	--

DEMARREUR - ANLASSER - MOTOR	STARTER MOTOR	MOTOR DE ARRANQUE	MOTORINO D'AVVIAMENTO	12 Volts
---	--------------------------------	------------------------------------	--	----------

MARQUE - HERSTELLER - MAKE - MARCA - MARCA	DUCELLIER	PARIS-RHONE
---	------------------	--------------------

REFERENCE - MARKIERUNG - REFERENCE - REFERENCIA - RIFERIMENTO	620 2-A	P8 E99
--	----------------	---------------

- Type - Intensité absorbée	- Typ - Stromaufnahme	- Type - Current	- Tipo - Intensidad absorbida	- Tipo - Intensità assorbita	280 A	330 à 340 A
- Pignon bloqué - Intensité absorbée à vide - Puissance maxi. - Couple à puissance maxi	- Ritzel blockiert - Stromaufnahme unbelastet - Maximale Leistung - Drehmoment maximale Leistung	- Pinion Locked - Current run at no load - Max. Power - Torque at maxi power	- Piñon bloqueado - Intensidad absorbida en vacío - Potencia máxi. - Par motor en potencia máxima	- Pignone bloccato - Intensità assorbita a vuoto - Potenza massima - Coppia a potenza massima	70 A	30 à 40 A
- Intensité absorbée par ce couple - Couple moyen à 1000 tr/mn.	- Drehmoment bei 1000 u/min.	- Current at this this torque - Mean torque at 1000 rpm	- Intensidad absorbida par este par. - Par motor medio a 1000 r.p.m.	- Intensità assorbita da questa coppia - Coppia media a 1000 giri/min	0,8 ch 0,25 m.kg (1.8 Ft.lbs)	1,12 ch 0,4 m.kg (2.9 Ft.lbs)
- Positionnement du démarreur - Réglage du lanceur	- Prüfmasse des Anlassers und des Anlasseritzels	- Positioning starter motor - Pinion settings	- Posición del motor de arranque - Reglaje del lanzador (bendix)	- Posizionamento del motorino d'avviamento - Regolazione del dispositivo d'imbocco	150 A 0,4 m.kg (2.9 Ft.lbs)	150 A 0,6 m.kg (4.34 Ft.lbs)
					$\left\{ \begin{array}{l} a = 1 \text{ mm} \\ b = 21 \text{ mm maxi} \end{array} \right.$	$\left\{ \begin{array}{l} a = 1,5 \text{ mm} \\ b = 21 \text{ mm maxi} \end{array} \right.$

- * - TYPE - A commande positive
- * - TYP = Serienmassig, mech
- * - TYPE = Pre-engaged
- * - TIPO De mando positivo
- * - TIPO A comando positivo

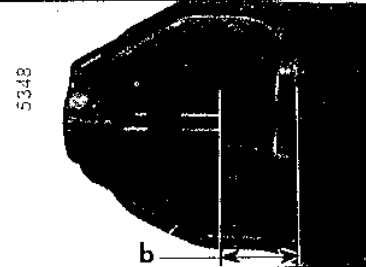
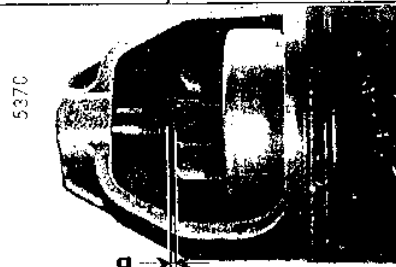

1	MANUEL DE REPARATIONS REPARATURHANDBUCH REPAIR MANUAL MANUAL DE REPARACIONES MANUALE DI RIPARAZIONE	N° 559/4	OPERATIONS ARBEITSVORGÄNGE OPÉRATIONS OPERACIONES OPERAZIONI	AM3.560-1	AMI 8	BERLINE (AM série JA) BREAK (AM série JB) BREAK COMMERCIAL (AM série JB) BREAK SERVICE (AM série JC) 9-1969 →
---	--	----------	---	-----------	--------------	---

ESSUIE - GLACE - SCHEIBENWISCHER - WINDSCREEN WIPER - LIMPIAPARABRISAS - TERGICRISTALLO

					12 Volts
Constructeur	Hersteller	Maker	Constructor	Costruttore	S.E.V. Marchal
Moteur	Motor	Motor	Motor	Motorino	Type 521
Référence	Markierung	Référence	Referencia	Riferimento	22 622
Entr'axes tringle de commande à chape (côté gauche)	Länge zwischen Gestänge u Gabelstück (links)	Centres of fork control linkage (left hand)	Entre eje, varilla de mando a chapa (lado izquierdo)	Interasse tiranteria di cdo (lato sinistro)	287,7 mm (11.5/16 in)
Entr'axes tringle de commande (côté droit)	Länge zwischen Gestänge (rechts)	Control linkage centres (right hand)	Entre eje varilla de mando (lado derecho)	Interasse tiranteria di cdo (lato destro)	286,7 mm (11.1/4 in)
Fin de course des balais (par rapport à la bordure inférieure du pare-brise)	Abstand der Wischerblätter vom unteren Rand der Windschutzscheibe	End of blade travel (in relation to lower edge of windscreen)	Fin de carrera de las escobillas (con relación al borde inferior del parabrisa)	Fine corsa delle spazzole (rispetto al bordo inferiore del parabrezza)	65 ± 10 mm (2.9/16 + 3/8 in)



1	MANUEL DE REPARATIONS REPARATURHANDBUCH REPAIR MANUAL MANUAL DE REPARACIONES MANUALE DI RIPARAZIONE	N° 559/4	OPERATIONS ARBEITSVORGÄNGE OPERATIONS OPERACIONES OPERAZIONI	AM3-510-1	AMI 8	BERLINE (AM série JA) BREAK (AM série JB) BREAK COMMERCIAL (AM série JB) BREAK SERVICE (AM série JC) 9-1969 
---	---	----------	--	-----------	-------	--

TABLEAU DES LAMPES - TABELLE DER GLÜHBIRNEN - BULBTABLE - CUADRO DE LAMPARAS - PROSPETTO DELLE LAMPADE

DESIGNATION BEZEICHNUNG FOR USE IN					DESIGNACIÓN DENOMINAZIONE		N B	TYPES DE LAMPES - TIPO DE LAMPARAS GLÜHBIRNENTYP - TIPO DI LAMPADA TYPE OF BULBS
Phare-code	Scheinwerfer Abblendlicht	Main/dip	Carretera Cruce	Abbaglianti Anabbaglianti	2			P4St 41 - 12 V - 45/40 W
Voyant de pression d'huile	Kontrolleuchte für Öldruck	Oil - pressure Warning Lamp.	Indicador de presion de aceite	Spia pressione olio	1		BA9S - 12 V - 1,5 W	
Plafonnier	Innenleuchte	Interior light	Luz interior	Plafoniera	1		NAVETTE - FESTOON - NAVETA NAVETTA - 12 V - 7 W	
Clignotants avant	Blinker, vorn	Flashers Front	Intermitentes delanteros	Lampeggiatori anteriori	2		BA 15S19 - 12 V - 21 W	
Clignotants arrière Stop	Blinker, hinter Stopplicht	Flashers Rear Stop	Intermitentes Traseros Stop	Lampeggiatori posteriori Stop	2 2		BA 15S19 - 12 V - 21 W BAY 15d/19 - 12 V - 21/5 W	
Lanternes arrière Eclairage de Plaque	Standlicht hinten Kennzeichen- beleuchtung	Rear lamps No. Plate lamp	Pilotos Traseros Alumbrado placa matrícula	Luci di posizione posteriori Illuminazione targa	2 2		BAY 15d/19 - 12 V - 21/5 W BA 15S/19 - 12 V - 5 W	
Eclairage de tableau de bord	Beleuchtung Armaturenbrett	Instrument Lighting	Alumbrado cuadro de abordo	Illuminazione cruscotto	1		BA9S - 12 V - 2WFB	
Lanternes avant	Standlicht vorn	Side lamps Front	Poblacion delantera	Luci di posizione anteriori	2		BA 15S/19 - 12 V - 5 W	

1	MANUEL DE REPARATIONS REPARATURHANDBUCH REPAIR MANUAL MANUAL DE REPARACIONES MANUALE DI RIPARAZIONE	N° 559/5	OPERATIONS ARBEITSVORGÄNGE OPERATIONS OPERACIONES OPERAZIONI	AM3. 721-0	AMI 8	BERLINE (AM serie JA) BREAK (AM serie JB) BREAK COMMERCIAL (AM serie JB) BREAK SERVICE (AM serie JC) 9 - 1969 
- CHASSIS -	FAHRGESTELL	- CHASSIS -	- CHASIS -	- TELAIO -		
Plateforme constituée par 2 longerons reliés entre eux par des entretoises et des planchers	Plattform mit 2 Holmen zusammenschweisst mit Traversen und Bodenblech	Platform made up of 2 sidemembers Joined With distance pieces and floor panels	Plataforma constituída por 2 largueros conectados entre ellos por traviesas y planchas de chapa.	Piattaforma costituita da due longheroni collegati da distanziali e da pianali		
Longerons } hauteur } largeur	Holme } Höhe } Breite	Sidemembers } height } Width	Largueros } altura } ancho	Longheroni } altezza } larghezza	106 mm (4 $\frac{3}{16}$ in) 60 mm (2 $\frac{3}{8}$ in)	
EPAISSEUR DES TOLES	BLECHSTÄRKEN	THICKNESS OF PANELS.	ESESOR DE LAS CHAPAS	SPESSORE LAMIERE		
Longerons extérieurs Longerons intérieurs Plancher supérieur Plancher inférieur Entretoise	Äussere Holme Innere Holme Oberes Bodenblech Unteres Bodenblech Traverse	Outer sidemembers inner sidemembers Upper floor Lower floor Distance pieces	Largueros exteriores Largueros interiores Plancha Superior Plancha Inferior Traviesa	Longheroni esterni Longheroni interni Pianale Superiore Pianale Inferiore Distanziale	1 mm (0.039 in) 0,7 mm (0.028 in) 0,9 mm (0.035 in) 0,8 mm (0.032 in) 0,6 à 1 mm (0.024 to 0.039 in)	
PORTE A FAUX DU CHASSIS NON CARROSSE :	ÜBERHANG DES RAHMENS OHNE AUFBAUTE KAROSSERIE :	OVERHANG OF CHASSIS WITHOUT BODY :	LONGITUD DE LOS LARGUEROS FUERA DE LA BASE DE LA PLATAFORMA :	SBALZO DEL TELAIO NON CARROZZATO :		
- vers l'avant - vers l'arrière	- Vorn - Hinten	- towards the front - towards the rear	- hacia adelante - hacia atrás	- anteriore - posteriore	0,513 m (20 $\frac{3}{16}$ in) 0,615 m (24 $\frac{3}{16}$ in)	
Longueur du chassis non carrossé toutes saillies comprises. Longeur du chassis non carrossé toutes saillies comprises	Länge des Rahmens (ohne Karosserie) einsch. Überstände Breite des Rahmens (ohne Karosserie) einsch. Überstände	Overall length of chassis without body including projections Overall width of chassis without body including projections	Longitud del chassis no carrossado todas las salientes comprendidas Ancho del chassis no carrossado todas las salientes comprendidos	Lunghezza del telaio non carrozzato compreso tutte le sporgenze Lunghezza del telaio non carrozzato compreso tutte le sporgenze	1,520 m (51 $\frac{11}{16}$ in) 1,420 m (55 $\frac{7}{8}$ in)	

1

MANUEL DE REPARATIONS
 REPARATURHANDBUCH
 REPAIR MANUAL
 MANUALE DE REPARACIONES
 MANUALE DI RIPARAZIONE

N° 559/3

OPERATIONS
 ARBEITSVORGÄNGE
 OPERATIONS
 OPERACIONES
 OPERAZIONI

AM3-721-0

AMI 8

BERLINE (AM série JA)
 BREAK (AM série JB)
 BREAK COMMERCIAL (AM série JB)
 BREAK SERVICE (AM série JC)

9-1969



CONTROLE D'UNE PLATEFORME
 KONTROLLE DES RAHMENS
 CHECKING OF A PLATFORM
 CONTROL DE UNA PLATAFORMA
 CONTROLLO DELLA PIATTAFORMA

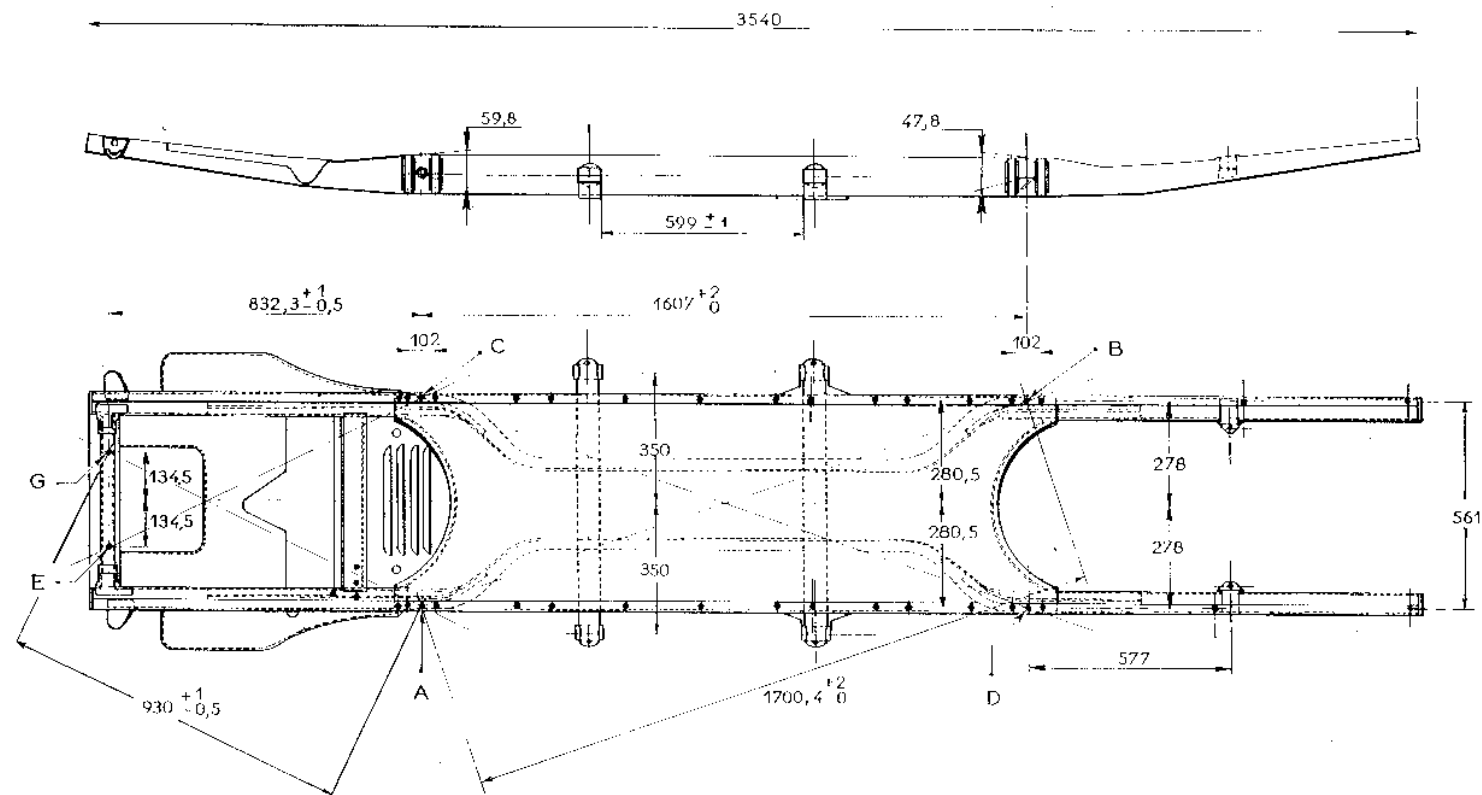

A. 72-57

1	MANUEL DE REPARATIONS REPARATURHANDBUCH REPAIR MANUAL MANUAL DE REPARACIONES MANUALE DI RIPARAZIONE	N° 559/1	OPERATIONS ARBEITSVORGÄNGE OPERATIONS OPERACIONES OPERAZIONI	AM3. 000 AMB3. 000 AM3. 100-00	AMI 8	BERLINE (AM série JA) BREAK (AM série JB) BREAK COMMERCIAL (AM série JB) BREAK SERVICE (AM série JC) 9 - 1969 
---	--	----------	---	--------------------------------------	-------	--

PNEUMATIQUES	REIFEN	TYRES	NEUMATICOS	PNEUMATICI
--------------	--------	-------	------------	------------

PRESSION DE GONFLAGE LUFTDRUCK INFLATION PRESSURE	PRESIONES DE INFLADO PRESSIONI DI GONFIAGGIO	en Kg/cm2	AVANT VORN FRONT	DEL ANT.	ARRIERE HINTEN REAR	TRAS. POST.	SECOURS - REPUESTO RESERVERAD - SCORTA SPARE
	125-380 X		1,800 (26 psi)		1,800 (26 psi)		2,000 (29 psi)
	135-380 X		1,400 (20 psi)		1,700 (25 psi)		1,900 (28 psi)

CAPACITES	FÜLLMENGEN	CAPACITIES	CAPACIDADES	CAPACITA'	
Réservoir essence Carter moteur - après - Vidange - après démontage des couvre-culasses - entre mini et maxi - Boîte de Vitesses - Freins	Kraftstoffbehälter Motorgehäuse - Nach Ölwechsel - Nach Abbau der Zylinder- kopfdeckel - Zwischen mini und maxi - Getriebe - Bremsen	Fuel tank Engine sump - after draining - after removal of cyl. head cover - between mins and max - Gearbox - Brakes	Depósito de gasolina Cárter motor - después de vaciado - después desmontaje tapas culatas - entre mini y máxi. - Caja de cambio - Frenos	Serbatoio carburante Carter motore - per sostituz.periodica - dopo smontaggio dei coperchi testata - fra minimo e massimo - Scatola cambio - Freni	31 l (6 3/4 Galb. Imp.) 2,2 l (3.9 pts. Imp.) 2,5 l (4.4 pts. Imp.) 0,5 l (7/8 pt. Imp.) 0,9 l (1.6 pts. Imp.) 0,5 l (7/8 pt. Imp.)
LUBRIFIANTS - Huile moteur - Huile boîte de vitesses - Graisse à cardans - Graisse à roulements - Liquide Freins	SCHMIERSTOFFE - Motoröl - Getriebeöl - Abschmierfett - Kugellagerfett - Bremsflüssigkeit	LUBRICANTS - Engine oil - Gearbox oil - Transmission grease - Bearing grease - Hydraul. brake fluid	LUBRIFICANTES - Aceite motor - Aceite caja de cambio - Grasa de transmisiones - Grasa de rodamientos - Líquido de frenos	LUBRIFICANTI - Olio motore - Olio scatola cambio - Grasso per giunti cardanici - Grasso per cuscinetti - Liquido per freni idraul.	TOTAL Altigrade GT speciale autoroute 20 w 40 TOTAL EP 80 TOTAL Multis TOTAL roulement TOTAL LHM

1	MANUEL DE REPARATIONS REPARATURHANDBUCH REPAIR MANUAL MANUAL DE REPARACIONES MANUALE DI RIPARAZIONE	N° 559/1	OPERATIONS ARBEITSVORGÄNGE OPERATIONS OPERACIONES OPERAZIONI	AM3. 000 AMB3. 000 AM3. 100-00	AMI 8	BERLINE (AM série JA) BREAK (AM série JB) BREAK COMMERCIAL (AM série JB) BREAK SERVICE (AM série JC) 9 - 1969 →
---	--	----------	---	--------------------------------------	-------	--

GRAISSAGE - SCHMIERUNG - LUBRICATION - ENGRASE - LUBRIFICAZIONE
ENTRETIEN - WARTUNG - MAINTENANCE - ENTRETENIMIENTO - MANUTENZIONE

Périodicité Schmierabstände Serv. Intervals Periodicidad Periodicità	OPERATIONS	ARBEITSVORGÄNGE	OPERATIONS	OPERACIONES	OPERAZIONI	LUBRIFIANTS OLD UND SCHMIERMITTEL LUBRICANT LUBRICANTE LUBRIFICANTI
						5000 10000 20000 3000 6000 12000 Kms MILES
	Vidange moteur 2500 km → 17-11-1969	Motorölwechsel 2500 km → 17-11-1969	Drain engine oil & refill 1500 MI → 17-11-1969	Cambio aceite motor 2500 km → 17-11-1969	Sostituzione olio motore 2500 km → 17-11-1969	TOTAL Altigrade GT spéciale autoroute 20 w 40
	Niveau boîte de vitesses	Getriebeölstand	Top-up gearbox	Nivel caja de cambio	Livello scatola cambio	TOTAL EP.80
	Axes de pivots d'essieu	Achsschenkelbolzen	Axle swivel pins	Ejes de pivote de mangueta	Perni dei pivots	TOTAL MULTIS
	Machoières à coulisse (transmission)	Gleitstücke der Gelenkwellen	Sliding splines (drive shafts)	Cartuchos de corredera (transmisión)	Manicotti scorrevoli (trasmissione)	TOTAL ROULEMENT
	Articulations et charnières	Gelenke und Scharniere	Clevises and hinges.)	Articulaciones y bisagras	Articolazioni e cerniere	TOTAL Altigrade GT spéciale autoroute 20 w 40
	Couteaux des bras de suspension	Kantenbolzen der Schwingarme	Knife edges on wheel arms	Cuchillos de los brazos de suspension	Coltelli dei bracci di sospensione	TOTAL EP 80
	Nettoyer la cartouche de filtre à air	Luftfilter reinigen	Clean air filter element	Limpieza del cartucho del filtro de aire	Pulizia cartuccia filtro aria	TOTAL MULTIS
	Vidange boîte de vitesses	Getriebeölwechsel	Drain gearbox oil & refill	Cambio aceite caja de cambio	Sostituzione olio scatola cambio	TOTAL ROULEMENT
	Cable d'embrayage	Kupplungsseil	Clutch cable	Cable de embrague	Cavo frizione	
	Cable compteur	Tachometerwelle	Speedometer cable	Cable cuenta kilometros	Cavo contachilometri	
	Vérifier le fonctionnement du clapet de reniflard (control de la dépression du carter moteur)	Funktion Entlüftungsventil prüfen (Kontrolle des Unterdruckes im Motorgehäuse)	Check breather valve (check vacuum in sump)	Verificar el funcionamiento de la válvula de reniflard (control de la depresión en el cárter motor)	- Verificare il funzionamento della valvola dello sfiatoio (controllo della depressione nel carter motore)	